

AUDIO ANALOGUE

soundpleasure

HIGH-END AUDIO ELECTRONICS
HANDCRAFTED IN ITALY

Bellini preamplifier
Virtual Battery off line power supply

Issue Date: June 2008

AUDIO FUTURA spa
Research & Development

E-Mail (support):
sblanda@audioanalogue.com
podesta@audioanalogue.com
saggini@audioanalogue.com
elia@audioanalogue.com

Introduction

To achieve the best performance in a high end chain, first noise and interferences must be reduced in all the parts and especially in the stages before power amplifier. In fact power amplifier will add his high gain to everything it sees at its input, that's say of course the signal but noise and interferences too! We've spoken of noise and interferences because both work to reduce the performances but they are due to different mechanisms.

Interferences are caused by external sources that inject some kind of unwanted signal into the unit, while noise is intrinsically generated in every electronic circuit by a lot of physical phenomenons (thermal noise, $1/f$ noise...). So even if we could completely eliminate interferences what would remain superimposed to the "good signal" is noise.

It's very important to differentiate noise and interferences because the treatments are different. To reduce noise we must choose appropriate components and appropriate components values and work on the schematics to reduce the effects of the noise on the signal. To reduce the interferences we must first understand which are the sources of the interferences, how they introduce their unwanted effects in our units and at what frequencies are generated.

Often the main interferences in an audio equipment are driven in by the main power supply that introduces interferences at both low and high frequencies. In fact the AC power supply is a fundamental 50Hz (60Hz) signal with a lot of high frequencies components. Nowadays, the high frequency components may be very high due to the increasing number of electronic products using switching power supply connected to the AC line and to the increasing number of electronic products working at very high frequencies. Even if high frequency interferences work well beyond the audio band, inter-modulation effects can easily drive disturbs in the 20Hz-20kHz range. Anyway the low frequency components of the AC line fall exactly in the audio band! In fact they are the main responsible of the annoying "hum" in the loudspeakers.

To reduce the "hum" problems the Printed circuit board must be well designed and the power supply of the circuit filtered and regulated appropriately. Anyway is very hard to completely eliminate the 50Hz/60Hz component. Perhaps that's why the scale of the frequencies axis in the audio measurements is often linear, in such way the low frequency part is simply invisible on the graphic!!

To reduce the high frequency components, the filtering process usually suffice to eliminate the problems on the circuit power supply but coupling capacitive effects and irradiations, which effects depend on the frequency can make the interference appear where we don't want!

Virtual battery

The target is to not have power supply interferences at all. The first step is to clean out the AC line, and this is what is done with an "AC filter". But the solution is always expensive and cumbersome if we use a filter for all the audio chain and anyway doesn't help in any way to eliminate the low frequencies problems. The perfect solution would be to not connect the unit to the AC line and take the supply from a battery, but this is impossible for power amplifier for evident reasons and not very useful for a preamplifier or audio source too.

To solve the problem we have designed a virtual battery power supply. That's said a circuit that insulate completely the preamplifier power supply from the AC main.

How can you see in the schematic, the AC main is filtered just as it reaches the board to eliminate any high frequency disturbs. Then the AC voltage is reduced by the transformer to be used on the board, rectified by the bridge and then filtered. Then we found two voltage regulators one for the positive voltage and the other for the negative. The *Area1* is "contaminated" by the 50Hz (60Hz) presence. What we have done in this part is trying to eliminate the interference as more as possible, designing two discrete components voltage regulators (voltage regulators 1 and 2) with very high 50Hz/60Hz noise rejection. Until now nothing new under the sun, because these solutions are present with better or worse results in every good preamplifier, the virtual battery comes beyond. What we want to do is to never connect in any way the preamplifier power supply stage (that supplies the preamplifiers, the input selection circuit and the volume circuit) to the 50Hz/60Hz area.

This is implemented supplying the Voltage regulators 3 and 4 by a capacitor bank of 156000 μ F(!!!!).

The circuit work as follows:

- at the turn on the control, that governs every switches and can sense the values of the voltage at the points V1 and V2, opens the switches 5, 6, 7 and 8 leaving the Voltage regulators 3 and 4 (and so all the preamp circuits) unpowered, while closing the switches 1, 2, 3, and 4. In such way after a delay all the capacitors in the four banks are charged.
- Then the control open the switches 1 and 3 and closes the switches 5 and 7. So the *Area2* is powered by the banks B1 and B3 but is disconnected from *Area1*. The voltage regulators 3 and 4 works consuming the charge stored in the capacitors of the banks B1 and B3. So the voltage at point V1 and V2 decrease.
- The control observes the voltage V1 and V2, and when they are too low the control switches off the switches 5 and 7 disconnecting the banks B1 and B3 from the *Area2*, switches off the switches 2 and 4 disconnecting the banks B2 and B4 from the *Area1* and then switches on the switches: 6, 8 (connecting banks B2 and B4 to voltage regulators 3 and 4). Then the control close the switches 1 and 3 connecting the banks B1 and B3 to the Voltage regulators 1 and 2 and charging again the capacitors of the two banks.

During the switching time the voltage at the input of Voltage regulator 1 and 2 is supplied by the capacitor C1 and C2.

Of course the story goes on cycle by cycle setting the appropriate voltage at the input of Voltage regulators 3 and 4.

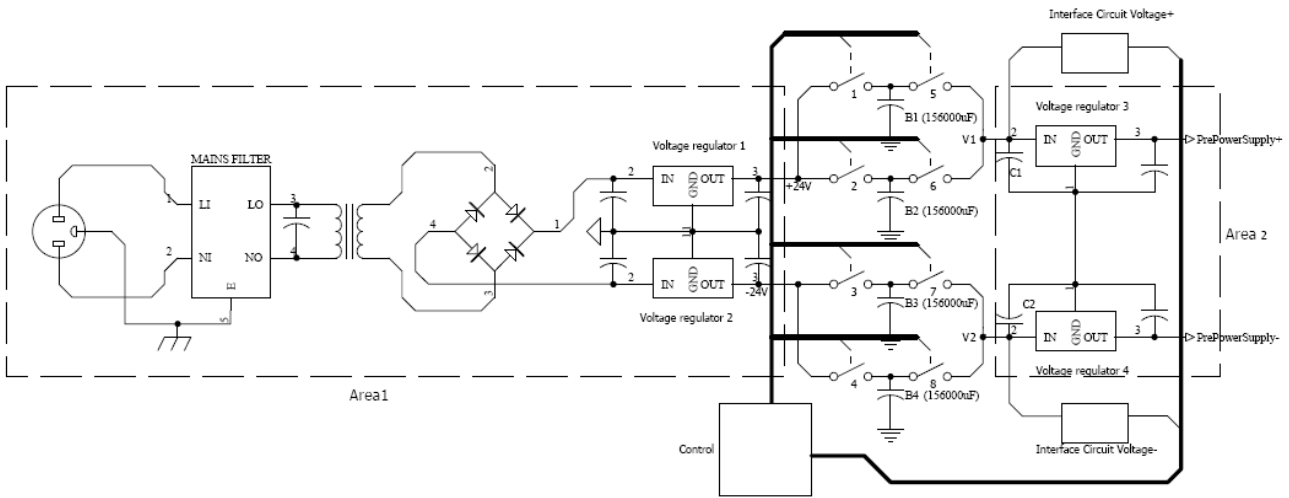
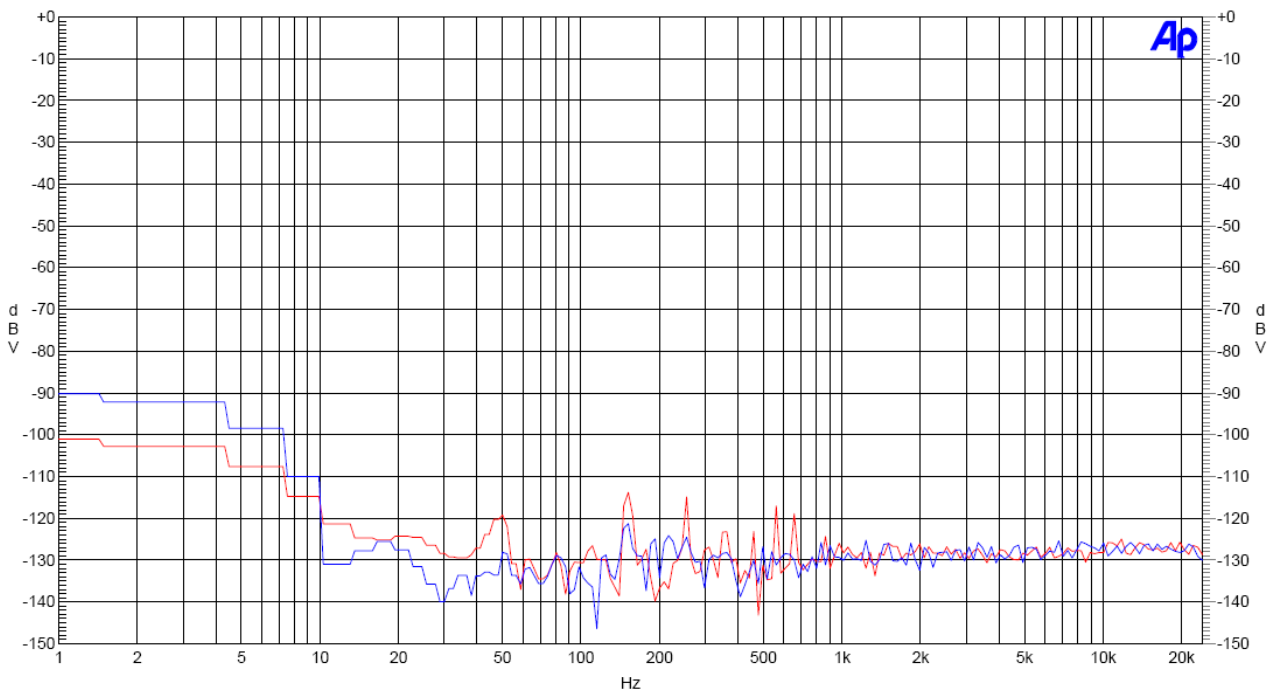

Fig. 1 - Schematic

The virtual battery works supplying all the preamplifiers circuits separately from the 50Hz/60Hz area eliminating in such way the 50Hz/60Hz interference. The high frequency interferences are stopped by the AC filter and also reduced by the virtual battery.

In the measurements beyond we can see the noise spectrum measured at the RCA output of the Bellini Virtual Battery Preamplifier with no signal applied. Its scale of the frequency axis is logarithmic to evidence the low frequencies range.



FFT Spectrum Analysis at Volume 0

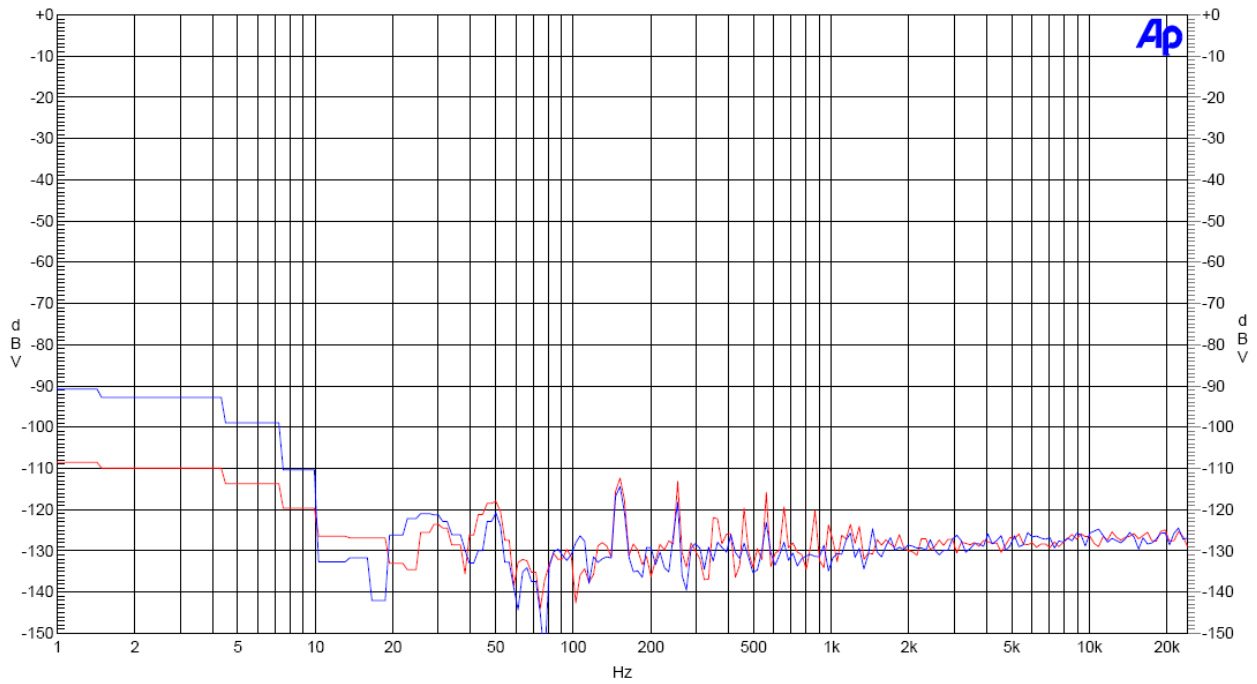

FFT Spectrum Analysis at Volume maximum

As you can see in the graphics the 50Hz component have been reduced to -120dB. Probably that value is due much more to the influence the cables (a standard RCA ones) get from the environment. So we can expect the preamplifier to have an even lower 50Hz component.