

# CLASSE

DELTA SERIES

**CP-800**

stereo preamplifier/processor





**CP-800**

stereo preamplifier/processor



The vast majority of high-end preamplifiers available today are direct descendants of products that have been made for decades, rooted in the world of analog sources. The CP-800 is something new. The CP-800 combines key building blocks of a contemporary high-end audio system in a unique way to improve and shorten the signal path.

New technology is applied to realize the benefits of modern computer-based audio. For the first time, a CD ripped to a computer has the potential to sound better than it could if played in a CD player; a Classé-designed Switch Mode Power Supply (SMPS) with Power Factor Correction (PFC) delivers higher performance at a lower price; convenient and feature-rich access to your music library is possible with simultaneous state-of-the-art playback; For the first time, there is no compromise at a reasonable price.

And there is much more...

#### COMPUTER AUDIO

With a CP-800\*, computer audio opens the door to a richer musical experience than audiophiles could have imagined only a few short years ago. It does so by combining superior performance with up to 192 kHz USB and DLNA Network-connected sources as well as AirPlay, with unfettered access to your music collection using a smartphone or tablet. A Classé App extends complete control of the CP-800 to any Network-connected iPad®, iPhone® or iPod touch®. Enjoy the expanded, rich experience of computer audio through the CP-800: convenience without compromise.

\*Original CP-800s may be upgraded to include 192 kHz USB, streaming audio and IP control for the Classé App.

#### BASS MANAGEMENT

When positioning left and right speakers, accepted practice is to give priority to symmetry and sound-staging—not low frequency performance. No matter how well your speakers reproduce bass, they are almost certainly not located in the optimum place in your room to do so. The solution is mono or stereo subwoofers, which until the CP-800, has always involved compromise. Although a stereo preamp, the CP-800 uses advanced Sigma DSPs to provide subwoofer outputs with selectable crossover frequencies and slopes in the digital domain prior to conversion to analog. The result is deep, smooth bass response without the compromise.

#### PEQ

Whether or not your speakers and subwoofer(s) are in the optimum location in the room, chances are there will be room modes that can only be addressed with equalization. In most rooms, the three primary dimensions contribute to three low frequency modes where the room actually reinforces the response at those frequencies. The CP-800 offers parametric equalization to help address these real world problems. Performed in the digital domain, these high quality filters allow optimization of low frequency response. No extra analog circuitry is required, nor is any compromise.





## ANALOG QUALITY

Make no mistake, the CP-800 is our best *analog* preamplifier ever. With pure Digital Bypass available for legacy sources (so pure, in fact, that when selected the digital clocks are turned off), fully balanced circuitry and completely isolated symmetrical left and right channels, your analog sources will sound better than ever. The CP-800 makes digital processing available to all sources, but when you want pure analog, there is no digital noise nor is there any compromise.

## TONE CONTROL

Banished from legitimate high-end preamps since the seventies, the tone control makes a come-back in the CP-800, but with a very modern implementation. In the past, tone controls required additional analog circuitry. The CP-800 introduces a flexible tone control feature that is entirely digital. If you've ever wanted to soften the top end of a recording a little or add a little warmth in the bottom, you will appreciate the convenience and subtlety of the CP-800's tone control feature. After more than forty years, the tone control is back, and now it works as intended: without compromise.

## HAVE IT ALL

The CP-800 puts world-class performance into one flexible and attractively priced chassis. Separate CD players and USB DACs require additional circuitry and interconnect cables plus a separate preamp, giving the CP-800 an obvious advantage in both performance and value. The additional features like AirPlay and DLNA compatibility, IP control using the Classe App, Bass management, PEQ and Tone Control make better real world performance and convenience a reality. If you are building a no-compromise high-end audio system, the CP-800 is unique. It is the first and still the only preamp/processor that lets you have it all.

Apple Certification is your indication that the Classé Design team has taken the time to make sure that the CP-800 works properly within the Apple ecosystem.



## Apple Certification

Recording music without storing and/or processing it in a computer is almost unheard of today. That has been the case for several decades now. What has changed are the ways in which consumers may access music and manage music files with their computers. Thanks to Apple's iconic iPod® and iTunes interface, and its subsequent string of smashingly successful innovations, computer audio for consumers has arrived.

Using a computer running iTunes, it is possible to copy CDs without losing any of the data. These full resolution files can be stored on your computer and played from its USB connector. Your computer gets connected to the corresponding USB connector located on the rear panel of the CP-800. If connected to a Network, Apple's AirPlay protocol seamlessly connects you and your music to the CP-800. Alternatively these music files may be loaded onto most iPod® and all current iPhone® and iPad® models\* to supply bit-perfect digital audio via AirPlay or using our USB host connector on the front of the CP-800.

The USB connector on the front of the CP-800 is dedicated to Apple portable devices. An Apple authentication chip inside the CP-800 enables the digital connection for music and allows charging of the device. The CP-800 remote can also provide basic transport controls through this connection.

\* See the "works with" listing in the specifications section for compatible models.

## Power Supply

The Classé Design team has developed a superb new Switch Mode Power Supply (SMPS). In addition to audio performance benefits described in a separate white paper, the SMPS is smaller, weighs less and is more efficient than conventional linear power supplies. With the very high dynamic range of today's best audio sources, the benefits of SMPS technology justify the effort required to implement it optimally.

The CP-800's SMPS provides four separate outputs: L&R analog circuits, digital circuits and the USB subsystem. An added benefit of this power supply design is that iOS devices including the iPad® (which requires a whopping 2.1 amps to charge at full power) may charge while connected to and playing through the CP-800.

The front panel USB connector is designed for use with Apple portable devices including the iPhone®, iPad® and most iPod® models\*



## Power Factor Correction (PFC)

Ideally, power would be pulled from the wall in a smoothly efficient manner. Since power is the product of voltage and current, it is easier (more efficient) to pull power from the wall by aligning current demands with the available voltage cycle. Power supplies without PFC only draw current during a brief period of the voltage cycle, resulting in greater peak current draw, lower efficiency and high frequency harmonics reflecting back onto the AC mains. (Fig.1)

Power Factor is the ratio of real power (power that the product actually uses) to the apparent power (power drawn from the AC mains). A power supply without PFC typically has a PF of about 0.6, indicating that a significant amount of energy is being wasted.

For the Classé SMPS, the PFC circuit achieves a Power Factor approaching unity, i.e. >0.95 at its working load. The circuit topology uses an active configuration that controls the amount of power drawn by the systems' load, allowing the current waveform to remain a smooth sine wave, in phase with the voltage. This allows the ratio of real power to apparent power to approach unity and avoids distortion of the voltage waveform. (Fig. 2)

In this way the CP-800 smoothly and efficiently pulls only the power it needs from the wall, performing its task unflinchingly for the CP-800 while causing no degradation of the power used by adjacent audio components.

Fig. 1: Voltage and Current without PFC

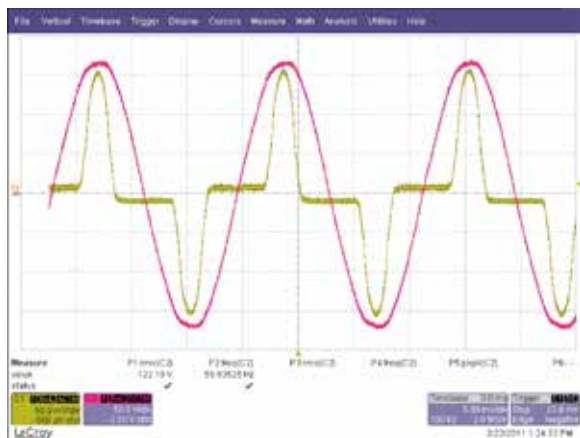
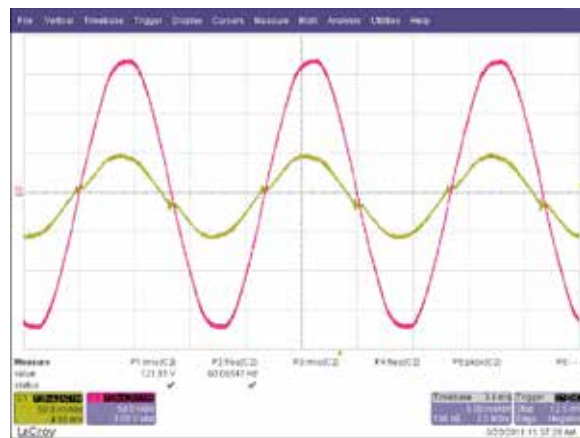

Fig. 2: Voltage and Current with PFC (CP-800)





## Network Audio

Music files stored on a computer or Network Attached Storage device can be played back through the CP-800 using the Network connection. Both AirPlay and DLNA sources are supported, so files of virtually every type and available resolution (up to 24-bit, 192 kHz) may be rendered via the Network connection.

A controller, such as iTunes, JRiver or PlugPlayer provides the organization and playback control of music files while the CP-800 appears as a renderer on the Network, accepting the streaming files, converting them to analog, setting the playback level and outputting the analog signal to your amplifier(s). All digital signals including those arriving via the Network connection are buffered using the Single Clock Substrate topology described separately.

## Synchronous USB (not used in the CP-800)

The problem posed by the standard USB/DAC approach is that the USB source (your computer or portable device) is ultimately responsible for the jitter in the system. Further, the USB source may degrade the performance of DACs, power supplies and analog circuitry by polluting the environment with noise coupling through power, control, signal and electromagnetic pathways.

Inside a USB/DAC is the USB microcontroller where the incoming audio data are loaded into a buffer. They are clocked out of the buffer into the DAC, synchronous to the USB source. In other words, the computer or portable device is in charge and as with S/PDIF, introduces jitter into the system that no amount of post processing can remove. The two clocks are kept synchronized by continually adjusting the rate of the clock pulling data out of the buffer and into the DAC. From an audio perspective, this approach is backwards as it forces the USB DAC to lock to a high jitter and compromised clock system.

This synchronous technique is also known as Adaptive USB, since the output rate adapts itself to the average rate of the incoming data. Given all the ways in which this basic approach is susceptible to noise and clock degradation, many tweaks may be applied upstream of the USB input that result in audible changes but do not solve the fundamental problem.

Fig. 3 Synchronous (Adaptive) USB

Fig. 4 Non-Optimal Asynchronous USB

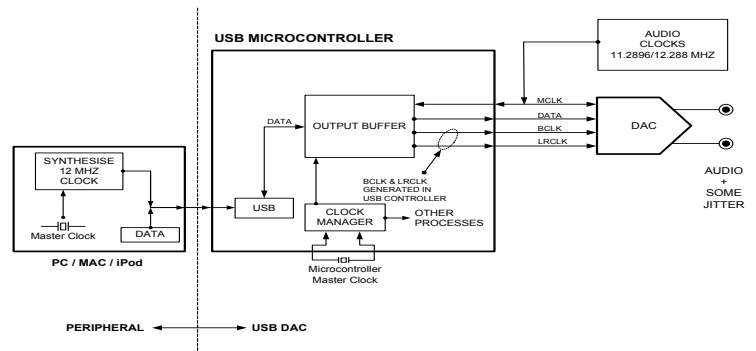
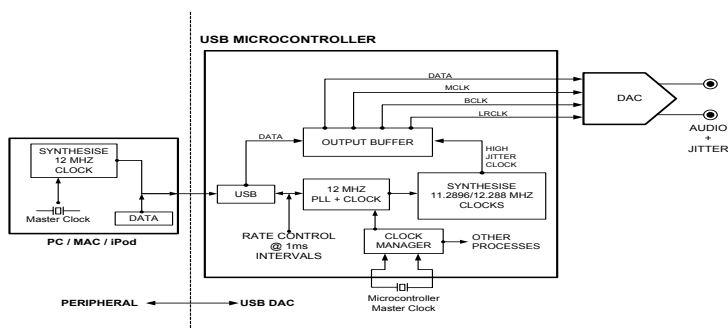



The USB subsystem uses galvanic isolation to prevent noise from connected USB devices from coupling into the audio circuitry.

## Asynchronous USB

Improvements to the performance of the USB subsystem are made possible by external control options offered with certain USB microcontroller chips. The most basic improvement involves taking charge of the clock. By controlling the clock locally in the USB/DAC, we make it asynchronous to the clock in the computer or portable USB device. The USB microcontroller now controls the flow of data from the source rather than the other way around. In the CP-800 dedicated master clocks are used for the different sampling frequencies. (Fig. 4)

With this technique, we can isolate the USB/DAC from noise propagated from the source. The CP-800 uses complete galvanic isolation, severing all electrical pathways from the source to ensure unwanted noise is kept out of the audio system. This is where most others stop. The Classé Design team, however, went further.

## Single Clock Substrate

There are several ways in which the performance of the master clock may be degraded. The CP-800 employs a technique we call Single Clock Substrate to ensure the best possible performance.

The USB microcontroller is itself a rather noisy place, with its own clock and that of the source device that's loading its buffer. These microcontrollers are good at many things, but keeping clocks isolated is not among them. You can partition functions on the silicon but you cannot completely isolate them.

The solution developed for the CP-800 was to place a Field Programmable Gate Array (FPGA) near the DACs and master clock oscillators. Data from the selected digital source on the digital input board are received and buffered by the FPGA located adjacent to the DACs on the motherboard. Data are transferred to the DACs synchronous to the CP-800 master audio clock (the only clock used in the FPGA). This topology ensures the greatest isolation of clocks and data from all upstream artifacts.

The digital signal, arriving at the DACs with all of the correct data, and timing that is as precise as it can be, is in position to be converted to analog. Up to this point, the CP-800 has managed to technically outperform even the best CD players.

Fig. 5 Optimal Asynchronous USB with FPGA (Single Clock Substrate)

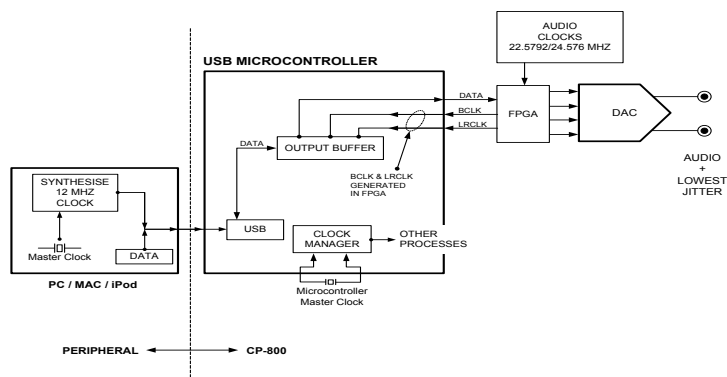

## The CP-800 introduces a new architecture for high-end preamplifiers.

### A few words about execution...

Details of the many different parts chosen for the CP-800 may be of interest to the technically inclined consumer, and the Classé Design team does nothing to conceal their identity. In fact, a list of parts and a schematic diagram would not be nearly enough information to reverse-engineer the CP-800 or duplicate its performance. There are exclusive Classé technologies employed in the FPGA (Single Clock Substrate) and power supply (SMPS with PFC) that are not readily apparent or discoverable. But if one were to ask which are the most important parts, the answer would be the circuit boards themselves. The power supply, digital input and motherboard are all six-layer circuit boards. (Fig. 6)

The layout of Classé-designed circuit boards is always done by hand. No computer programmed auto-routing scheme could approach the results possible when each part, pad, plane and trace is painstakingly considered and located for optimal performance. This time-consuming approach is costly, but there is no substitute. Literally thousands of decisions are made that, taken in isolation, may or may not be audible. Taken as a whole, these decisions make all the difference. Through the difficult work of pcb layout, the Classé Design team transforms a schematic diagram and component parts into a synchronized and functional electronic masterpiece. Add in proprietary Classé technology and the CP-800 has no peer.

### Summary

By combining the functions of a Network renderer, USB DAC, digital processor and analog stereo preamplifier in a way that optimizes the performance of every source, the CP-800 offers a unique solution for the most demanding audiophile.

Benefits include:

- Streaming from computer, NAS, tablets and iOS devices via a robust, wired Network connection.
- A shorter, more direct signal path than any combination of CD player or USB DAC and stereo preamplifier.
- Asynchronous handling of computer-based USB audio sources using Classé-developed Single Clock Substrate technology.
- Optimized handling of legacy analog and digital sources.
- Highly efficient, high-performance, Classé-designed power supply that is quiet inside the chassis and a good neighbor to other system components.
- Performance-enhancing processing benefits available to all sources, including parametric EQ, tone control, bass management with selectable crossover points and slopes.

Fig. 6 Signal Routing CP-800 Motherboard



The CP-800 introduces a new architecture for high-end preamplifiers. Capitalizing on the potential for computer-based audio and employing powerful processing tools, the CP-800 offers compelling performance, features and value.



An optional high-performance Phono Preamp Module (PPM) may be installed in the CP-800. It supports both MM and MC type cartridges and custom loading. See your Classé dealer for details.



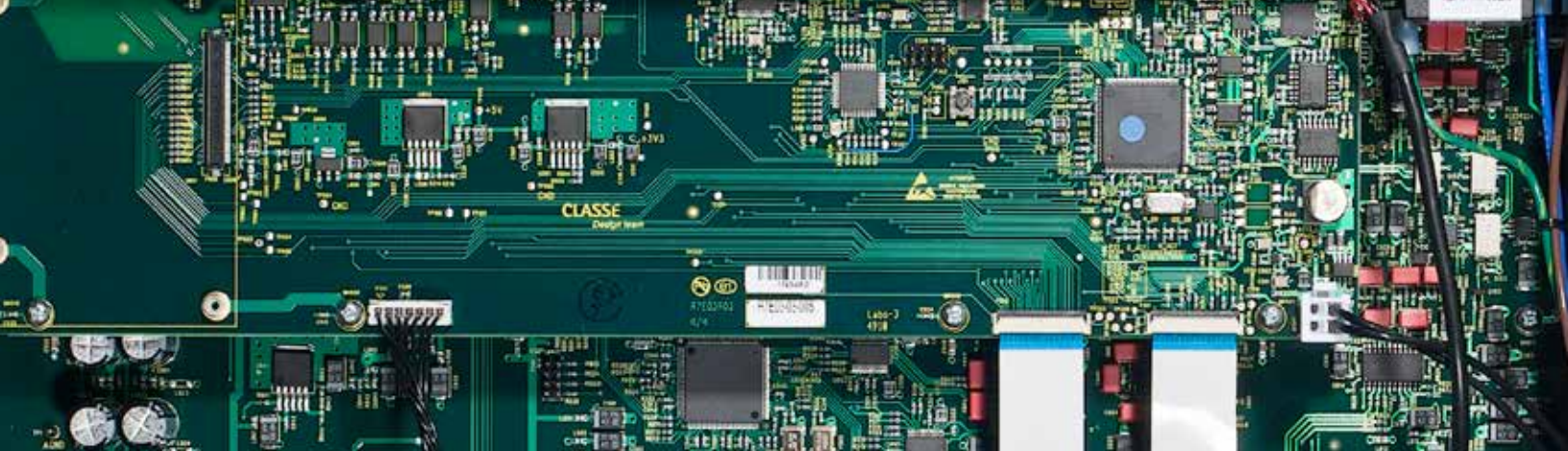

## Specifications

<b>Frequency response</b>	8 Hz - 200 kHz < 1 dB, stereo digital bypass 8 Hz - 20 kHz < 0.5 dB, all other sources	<b>Standby power consumption</b>	<1 W
<b>Channel Matching</b> (left to right)	better than 0.05 dB	<b>Rated power consumption</b>	53 W
<b>Distortion</b> (THD+noise)	.0005%, digital source/bypassed analog source .002%, processed analog source	<b>Mains Voltage</b>	90-264 V, 50/60 Hz
<b>Maximum input level</b> (single-ended)	2 Vrms (DSP), 4.5 Vrms (bypass)	<b>Overall dimensions</b>	Width: 17.5" (445 mm) Depth: 17.5" (445 mm) (excluding connectors) Height: 4.78" (121 mm)
<b>Maximum input level</b> (balanced)	4 Vrms (DSP), 9 Vrms (bypass)	<b>Net weight</b>	23 lbs (10.43 kg)
<b>Maximum output level</b> (single-ended)	9 Vrms	<b>Shipping weight</b>	33 lbs (15 kg)
<b>Maximum output level</b> (balanced)	18 Vrms	<b>Made for</b>	iPod touch (5th generation) iPod nano (7th generation) iPod touch (4th generation) iPod nano (6th generation) iPod touch (3rd generation) iPod nano (5th generation) iPod touch (2nd generation) iPod nano (4th generation) iPod touch (1st generation) iPod nano (3rd generation) iPod classic iPod nano (2nd generation)
<b>Gain Range</b>	-100 dB to +14 dB	<b>Made for</b>	iPhone 5 iPhone 3GS iPhone 4S iPhone 3G iPhone 4 iPhone
<b>Input impedance</b>	50 k $\Omega$ (balanced) 100 k $\Omega$ (single-ended)	<b>Made for</b>	iPad (4th generation) iPad 2 iPad (3rd generation) iPad iPad mini
<b>Output impedance</b> (main output)	300 $\Omega$ (balanced), 100 $\Omega$ (single-ended)	<b>Airplay</b>	Airplay works with iPhone, iPod, and iPod touch with iOS 4.3.3 or later, Mac with OS X Mountain Lion, and Mac and PC with iTunes 10.2.2 or later.
<b>Signal-to-noise ratio</b> (ref. Bal. 4 Vrms input, unweighted)	104 dB, bypassed analog source 101 dB, processed analog source 105 dB, digital source (ref. full-scale input, unweighted)		
<b>Channel separation</b>	better than 100 dB		
<b>Crosstalk</b> (any input to any output)	better than -130 dB @ 1 kHz		





## CP-800

stereo preamplifier/processor

Classé and the Classé logo are trademarks of B&W Group Ltd.  
All rights reserved.

"Made for iPod," "Made for iPhone," and "Made for iPad" mean that an electronic accessory has been designed to connect specifically to iPod, iPhone, or iPad, respectively, and has been certified by the developer to meet Apple performance standards. Apple is not responsible for the operation of this device or its compliance with safety and regulatory standards. Please note that the use of this accessory with iPod, iPhone, or iPad may affect wireless performance.

iPhone, iPod, iPod classic, iPod nano, and iPod touch are trademarks of Apple Inc., registered in the U.S. and other countries. iPad is a trademark of Apple Inc.



Prices and specifications subject to change.  
We are not responsible for typographical errors.  
Printed in Canada on recycled stock.





A tall, narrow wooden speaker with four drivers, including a tweeter, two midrange drivers, and a woofer. It is positioned on the left side of the room, near the window.

A decorative wooden sculpture consisting of a vertical stack of approximately 12 rectangular wooden boxes of varying sizes. Some of the boxes are illuminated from within, creating a warm, glowing effect. The sculpture is mounted on a wall made of light-colored stone.

A tablet computer displaying a grid of colorful icons, likely a home screen or a menu. It is placed on top of a wooden cabinet.

A built-in oven with a white front panel and a black control panel. The control panel features a digital display showing "-28.0" and a large knob. The oven is integrated into a wooden cabinet.



# CLASSE

**USA & Canada • B&W Group Ltd.**

5070 François Cusson • Lachine • Québec • Canada • H8T 1B3

Tel +1.514.636.6384 • Fax +1.514.636.1428

[www.classeaudio.com](http://www.classeaudio.com) • email: [cservice@classeaudio.com](mailto:cservice@classeaudio.com)