



ELECTROCOMPANIET

If music really matters...



ECD 1

Owner's Manual



Owner's Manual

ECD 1

24 Bit Upsampler 192kHz DAC

Warning:

To avoid risk of fire or electric shock, do not expose this appliance to rain or moisture.

Verify line voltage before use.

Do not remove cover. No user serviceable parts inside. Refer servicing to qualified service personnel.

The warranty is void if the product is tampered with by non-authorized personnel.

Use only authorized Electrocompaniet service center.

Unpacking the ECD 1

Immediately upon receipt of the ECD 1, inspect the carton for possible damage during shipment. The carton and packaging have been designed to provide the safest possible protection for the transport of your product. Unpack the unit carefully. Save all packaging materials for future shipment.

The contents of the carton

1 pcs Electrocompaniet ECD 1

1 pcs AC main cord

1 pcs inspection card

Setup procedure

Before connecting the ECD 1 to the mains, check that the mains voltage indicated on the rear panel corresponds to the line voltage in the territory you intend to use the unit.

How to avoid damages

Do not under any circumstances connect or disconnect equipment when power is turned on. The design of the RCA plug generates a huge transient when inserted. Connecting or disconnecting equipment with the power on can result in severe damage to both speaker and amplifier.

How to avoid noise problems

The ECD 1 contains delicate circuits that are sensitive to magnetic strayfields. The unit should not be placed near mains transformers, TV sets etc. Care should be taken regarding placement of the interconnect cables. Do not run interconnect cables in parallel with main cords or speaker cables. Keep interconnect and speaker cables as short as possible.

How to avoid antenna problems

In some set-ups hum may occur when you connect the radio, VCR or TV to your system. The problem is caused by DC voltage coming from your antenna. Please contact your cable network operator.

How to connect your system

Please read this page carefully and follow page 8-10.

Inputs

All digital inputs are electrical equal, and will accept the following:

RCA	(S/PDIF)
XLR	(AES/EBU)
OPTICAL	(TOSLINK)

Outputs

Analogue outputs

XLR	(BALANCED)
RCA	(SINGLE ENDED)

Digital outputs

RCA and OPTICAL (S/PDIF,TOSLINK)

Both outputs may be used simultaneous.

The output will follow the selected input.

The ECD 1 can be used as a switch for multi-channel source (DVD).

See page 10

How to power up your system

You should always power up your system the following way:

Signal sources (CD player, tuner,dac etc.) first. Then turn on the preamplifier. Allow 30 seconds of preheating before you turn on the power amplifier. After switching on the power amplifier, there will be a 5 seconds delay before the speakers are connected. This will prevent large turn on/off transients to reach the speakers.

When turning your system off, you should start by switching off your power amplifier, then the preamplifier, and finally the signal source devices.

Warning

The product will be warm.

Due to the high class A operating point used in the Electrocompaniet design, it is normal that the product feels warm. Proper ventilation will be needed, and the product should not be covered. A good rule is to allow 1-2 inches of air sidewise, and 2-3 inches above the product.

Technical Specification ECD 1

The following technical data were measured on randomized test objects and are typical data.

All measurements are made at 120V / 240V // 50Hz / 60Hz

Analog stage

Output level (unbalanced).....	1,6 V
Output level (balanced).....	3,2 V
Gain (unbalanced).....	1.6 X (4 dB)
Gain (balanced).....	3.2 X (10 dB)
Maximum output (balanced).....	> 14 V RMS
THD (1 V out, 1 kHz).....	< 0.002 %
Channel separation (1 V out, 1 kHz).....	> 90 dB
Equivalent input noise.....	4 uV
Output impedance.....	100 Ohm
Analog filter (-3 dB).....	75 kHz

Digital stage

Dig.inputs.....	XLR-AES/EBU, RCA, OPTICAL TOSLINK
Dig.outputs.....	RCA, OPTICAL TOSLINK
Dynamic range.....	100 dB
Signal to noise.....	100 dB
THD.....	-100 dB
Frequency response.....	20 Hz - 20 kHz
Input / Output impedance (fixed).....	75 Ohm
Sampling frequency in.....	32 - 48 kHz
Power consume.....	15 W

Dimensions

Width	483mm	(19")
Depth	255mm	(10")
Height	83mm	(3.2")
Weight	5kg	(11lbs)

The manufacturer reserves the right to alter these specifications without further notice

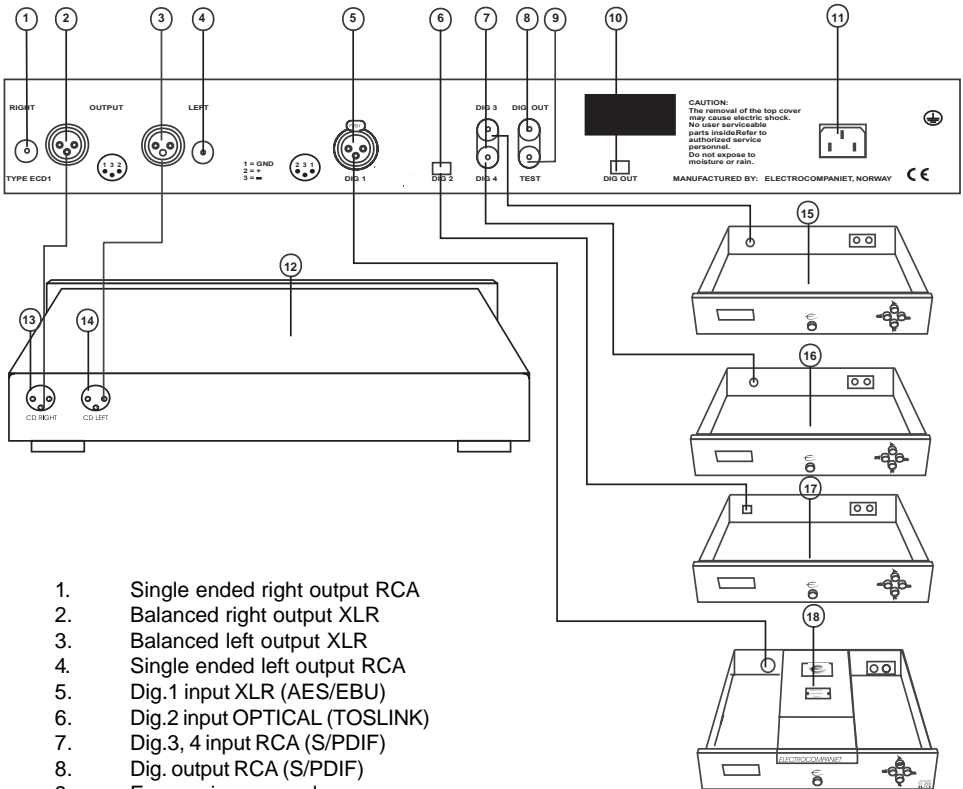

1. Single ended right output RCA
2. Balanced right output XLR
3. Balanced left output XLR
4. Single ended left output RCA
5. Dig.1 input XLR (AES/EBU)
6. Dig.2 input OPTICAL (TOSLINK)
7. Dig.3, 4 input RCA (S/PDIF)
8. Dig. output RCA (S/PDIF)
9. For service use only
10. Dig. output OPTICAL (TOSLINK)
11. Main AC inlet
12. **Balanced Preamplifier/Integrated Amplifier**
13. Balanced right input XLR
14. Balanced left input XLR
15. **Digital Versatile Disc player (DVD)**
16. **Laser Disc player (LD)**
17. **Digital Audio Tape player (DAT)**
18. **Compact Disc player (CD)**

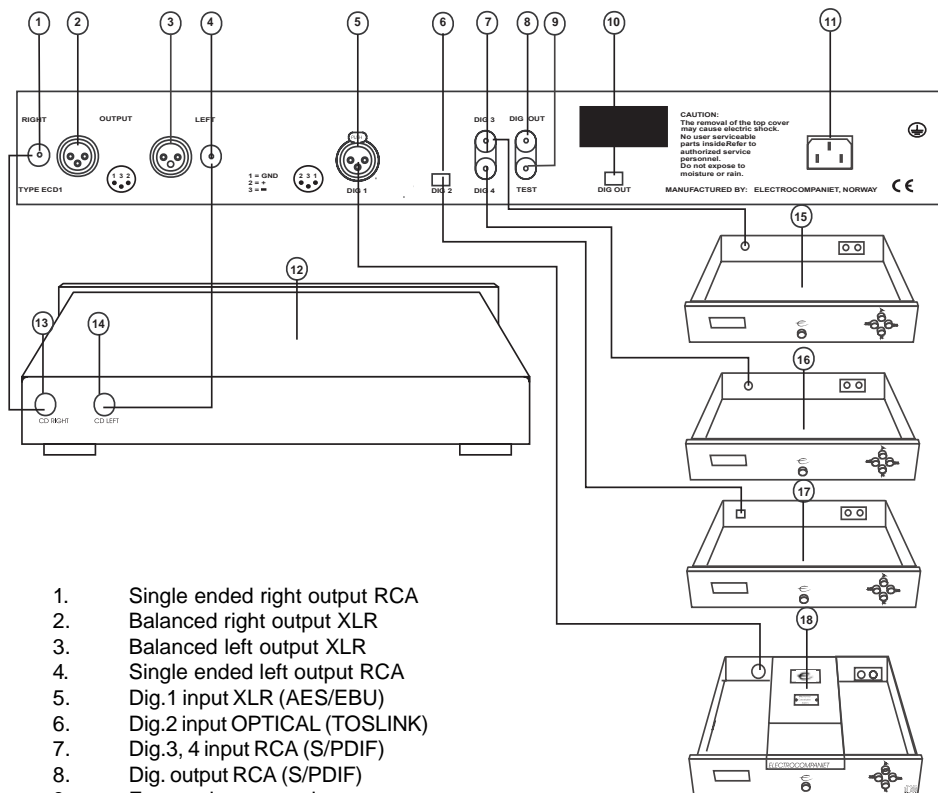

1. Single ended right output RCA
2. Balanced right output XLR
3. Balanced left output XLR
4. Single ended left output RCA
5. Dig.1 input XLR (AES/EBU)
6. Dig.2 input OPTICAL (TOSLINK)
7. Dig.3, 4 input RCA (S/PDIF)
8. Dig. output RCA (S/PDIF)
9. For service use only
10. Dig. output OPTICAL (TOSLINK)
11. Main AC inlet
12. **Preamplifier/Integrated Amplifier**
13. Balanced right input XLR
14. Balanced left input XLR
15. **Digital Versatile Disc player (DVD)**
16. **Laser Disc player (LD)**
17. **Digital Audio Tape player (DAT)**
18. **Compact Disc player (CD)**

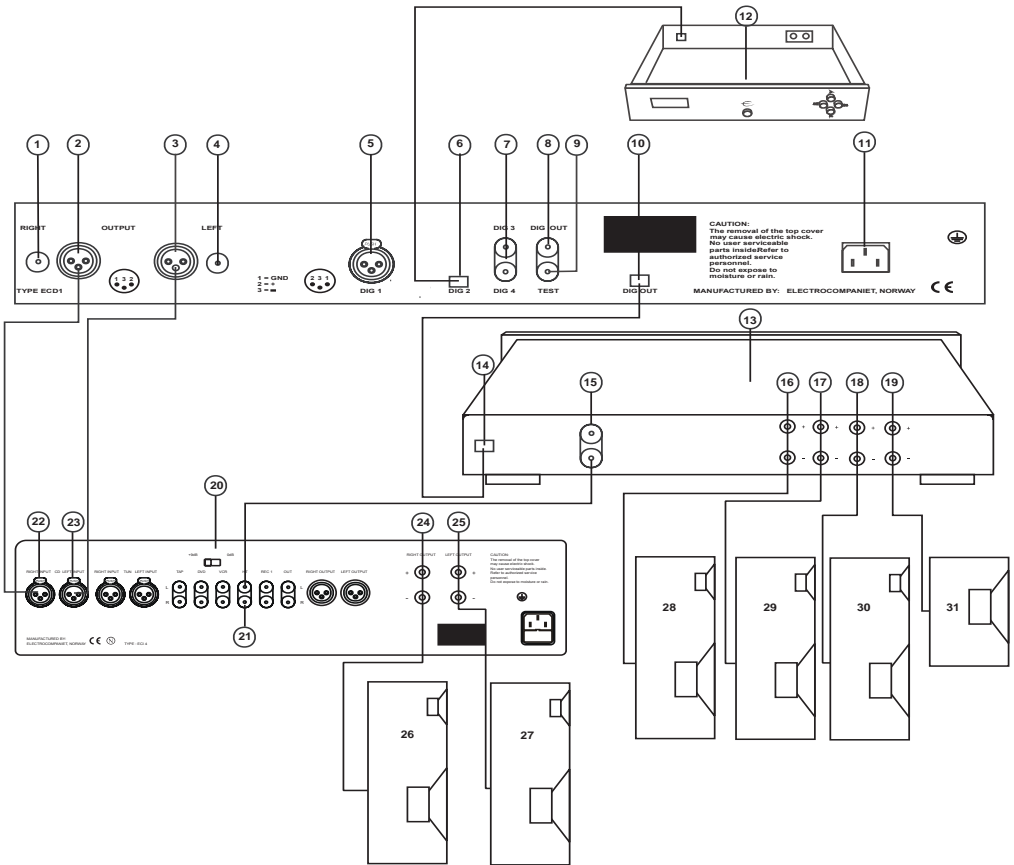

- | | | | |
|-----|--|-----|---|
| 1. | Single ended right output RCA | 16. | Right rear output |
| 2. | Balanced right output XLR | 17. | Left rear output |
| 3. | Balanced left output XLR | 18. | Center output |
| 4. | Single ended left output RCA | 19. | Sub. output |
| 5. | Dig.1 input XLR (AES/EBU) | 20. | Pre-amplifier/Integrated Amplifier |
| 6. | Dig.2 input OPTICAL (TOSLINK) | 21. | Home Theater input |
| 7. | Dig.3, 4 input RCA (S/PDIF) | 22. | Balanced right input XLR |
| 8. | Dig. output RCA (S/PDIF) | 23. | Balanced left input XLR |
| 9. | For service use only | 24. | Right front output |
| 10. | Dig. output OPTICAL (TOSLINK) | 25. | Left Front output |
| 11. | Main AC inlet | 26. | Right front loudspeaker |
| 12. | Digital Versatile Disc player (DVD) | 27. | Left front loudspeaker |
| 13. | Surround Receiver/Preamplifier | 28. | Right rear loudspeaker |
| 14. | Dig input (Dolby Digital,DTS) | 29. | Left rear loudspeaker |
| 15. | Pre-out Front | 30. | Center loudspeaker |
| | | 31. | Sub. loudspeaker |