

Installation/Operating Instructions

Phantom Video Projector Lift by Draper

These Installation/Operating Instructions are available in the official language of the country where you purchase the product. Please contact your distributor to request a copy.

Vous pourriez demander les instructions d'installation et d'opération traduites dans la langue officielle du pays où vous achetez le produit. Veuillez demander à votre distributeur.

Die Gebrauchsanweisung für Installation und Konstruktion sind in der offiziellen Sprache des Landes, indem Sie das Produkt gekauft haben, vorhanden. Fragen Sie die jeweilige Verkaufs-Abteilung.

Caution

- 1 Read instructions completely before proceeding.
- 2 Follow instructions carefully. Installation contrary to instructions invalidates warranty.
- 3 Do not obstruct operation of the lift with fingers or any other object. Serious injury or damage could result.
- 4 Entire bottom of unit must be unobstructed to permit proper operation.
- 5 Unit must be installed level (use a carpenter's level).
- 6 Unit operates on 24V DC.

Note: Unit has been thoroughly inspected and tested at factory and found to be operating properly prior to shipment.

Planning

- 1 Based on screen location and projector specifications, determine proper position for projector installation.
- 2 Confirm that there is adequate space for installation and operation.
- 3 Arrange to provide service access to the unit.
- 4 Total lifting capacity of lift is 26 lbs (11.8 kg), including projector.

As Soon As Phantom Projector Lift Arrives

- 1 Open carton and inspect for damage.
- 2 Locate the following parts:
 - A. The unit itself
 - B. Controls
 - C. Any optional equipment
- 3 Test unit before installing.

Hanging Unit

The Phantom is provided with four (4) mounting points for suspending the unit from above. The unit should be guy wired or blocked to prevent swinging. All installations should observe the following guidelines:

- 1 Installer must ensure that all fasteners and supports are of adequate strength to securely support Phantom and projector. It is recommended that hardware structure be able to hold at least four times the combined weight of the lift and projector.
- 2 Fastening methods must be suitable for mounting surface, and securely anchored so vibration or abusive pulling on unit will not weaken installation.

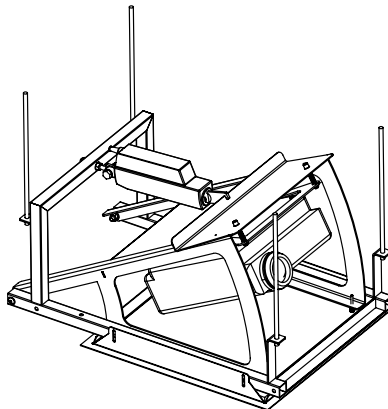

- 3 Bottom of unit must be unobstructed after installation.
- 4 Do not use unit to support adjacent ceiling, light fixtures, etc.
- 5 Do not complete the ceiling below unit until electrical connections have been completed and unit has been operated successfully.

Electrical Connections

Unit operates on 24V DC.

The Phantom is shipped closed.

Please note: Make sure electrical supply has been disconnected before attempting to connect Phantom to electricity.

Connections should be made in accordance with wiring diagram, and wiring should comply with national and local electrical codes. All operating switches should be "off" before power is connected.

110V or 220V AC for projector must be supplied by others. Phantom should be operated and checked prior to installing projector.

Operation

Unit is automatically supplied with a double pole double throw switch. When unit is first operated, be cautious! If unit fails to operate when the switch is flipped "down", return switch to "off" and recheck electrical connections before proceeding. Cycle unit down and up several times to confirm satisfactory operation.

Optional DC Motor Control (Not CE Approved)—Optionally available to allow remote control, RS232 or Ethernet connection.

Optional Infrared or Radio Frequency Remote Control (Not CE Approved)—If ordered, a three-button transmitter is provided, with "up", "down", and "stop" buttons. Unit starts opens or closes when appropriate button is pressed, and may be stopped by pressing "off" button. When using RF or IR control, a three-button up-stop-down wall switch is also recommended and optionally available. DC Motor Control required.*

Optional RS232/Ethernet (Not CE Approved)—Serial communication and network communication optionally available with wall switches, RF or IR remote. When using RS232 or Ethernet control, a three-button up-stop-down wall switch is also recommended and optionally available. DC Motor Control required.*

*** Please Note: If unit is being operated using RF, IR, RS232 or Ethernet, but you still wish to have a wall switch, the standard double pole, double throw switch provided with the lift will not work. You must use the optional three-button up-stop-down switch.**

Phantom Operation

Closed

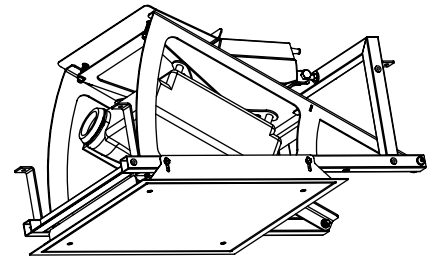

Open

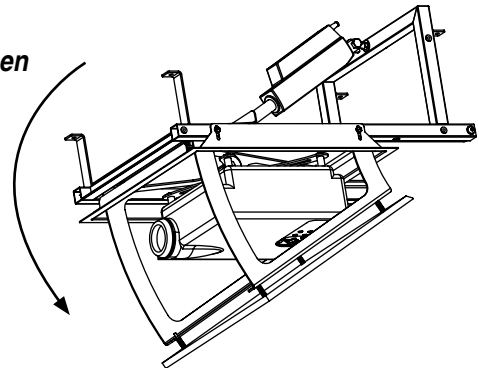

DRAPER®

411 S. Pearl St., Spiceland, IN 47385 USA ■ 765-987-7999

www.draperinc.com ■ fax 765-987-7142

Copyright © 2008 Draper Inc. Form Phantom_Inst08 Printed in U.S.A.

If you encounter any difficulties installing or servicing your Phantom projector lift, call your dealer or Draper, Inc. in Spiceland, Indiana, 765-987-7999, or fax 765-987-7142. Outside the United States, fax (765) 987-1689.

Phantom with Plenum

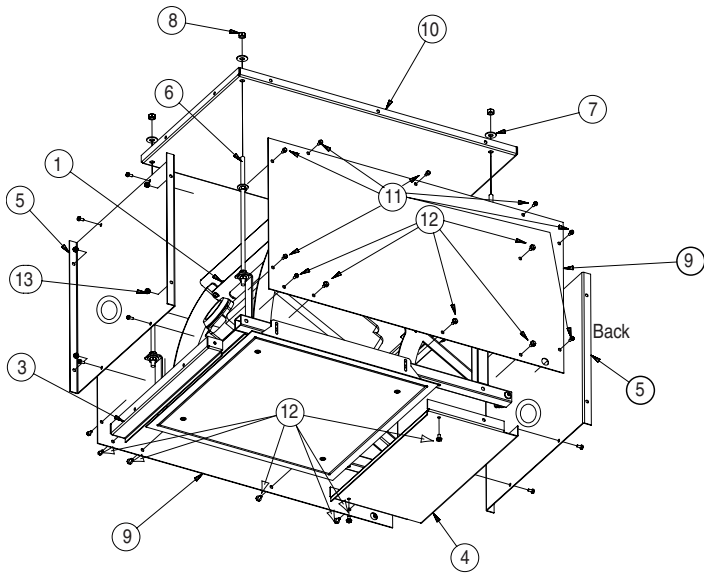

Item	Quantity	Description
1	1	Phantom
2	1	Phantom plenum (individual pieces below)
3	1	Lower Front Plenum Panel
4	1	Lower Rear Plenum Panel
5	2	End Plenum Panel
6	4	5/16" (7.9 mm)-18 Zinc Threaded Rod
7	16	Zinc Flat Washer
8	16	5/16" (7.9 mm)-18 Zinc Hex Nut
9	2	Side Plenum Panel
10	1	Top Plenum Panel
11	24	#8-32 x.375 (9.5 mm) Zinc Hex Head Screw/Washer
12	12	#10-32 x.375 (9.5 mm) Zinc Hex Head Screw/Washer
13	16	#8-32 Zinc Keps Nut

Phantom—Dimensions

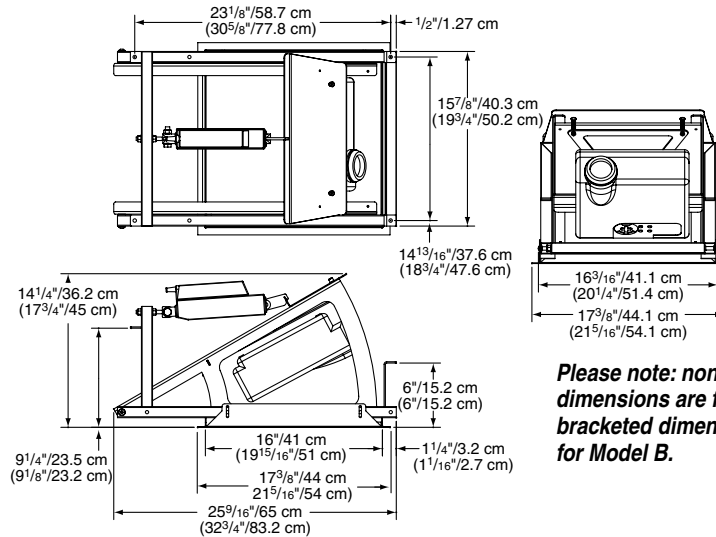

Phantom with Plenum—Dimensions

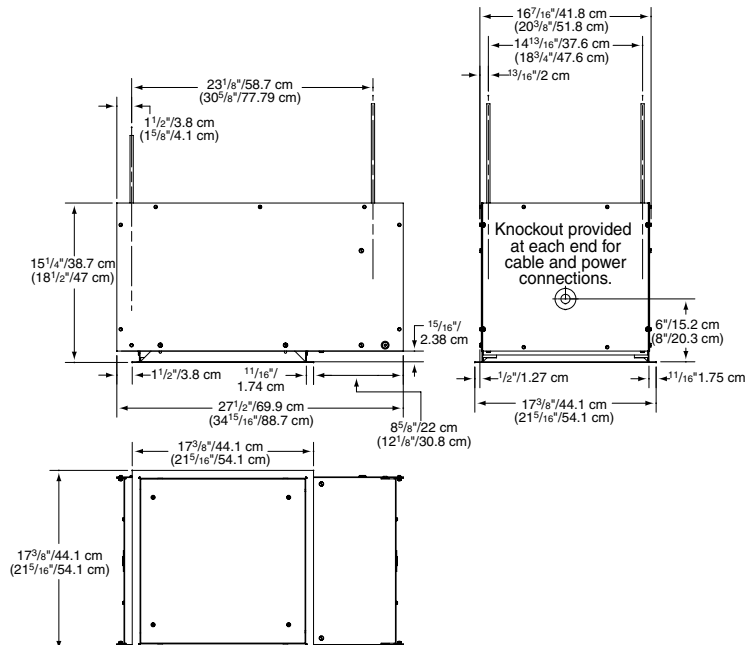

Projector Installation

The Phantom video projector lift uses the Skyhook projector mount system. The parts kit contains:

- Two long skyhook arms
 - Four short skyhook arms
 - Four M3, four M4, four M5 & four M6 mounting bolts (30 mm)
 - Four spacers (1/2" [12.7], 5/8" [15.875], 3/4" [19.05], 7/8" [22.225 mm])
- ① Determine which size mounting bolts suit your projector, and set others aside. They are no longer required. If your projector has only three mounting holes, set aside one of the skyhook arms.
 - ② Assemble the universal mount (see diagram at right) using arms appropriate to projector. Spread out the arms so each end is over one of the mounting holes.
 - ③ Connect universal mount to Projector. Fit the 1/2" (12.7 mm) spacer under the lowest arm, the 5/8" (15.875 mm) under the next arm and so on. If the projector base is uneven, you may use combinations of spacers and arms to ensure the triangular plate is horizontal.
 - ④ Do not tighten any bolts yet.
 - ⑤ Move the position of the triangular plate over the center of the projector, with the edge with the two holes towards the front (lens).
 - ⑥ Tighten the mounting bolts. The projector and universal mount are ready to be inserted into the Phantom.
 - ⑦ First ensure that the Phantom is operating correctly, and that the projector cables are properly secured. Open the Phantom and insert the triangular projector plate into the slot in the rear of the Phantom. Attach it at the front using the supplied 1/4" (6.35 mm)-20 bolts and springs.
 - ⑧ These bolts will also give you Roll and Tilt adjustment to align your image on the screen, while the center 5/16" (8 mm) bolt provides Yaw adjustment. The springs will ensure that the projector is held still during motion. Do not install the projector plate without springs.

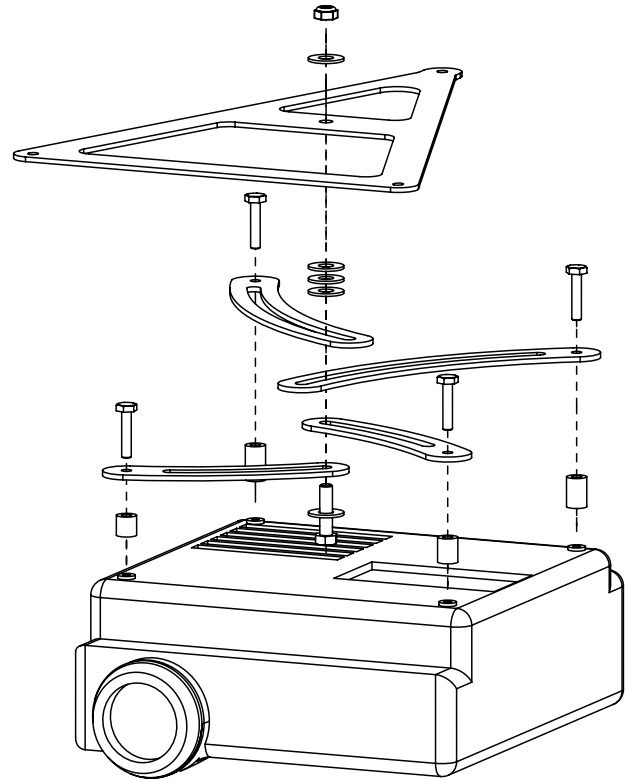

Cable Management

A cable exit hole is pre-drilled in the top panel. Make sure to leave enough slack in the cable to account for the motion of the Phantom during operation.

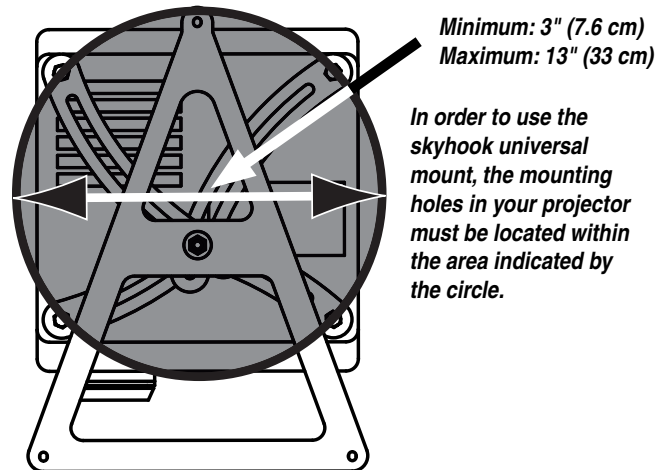
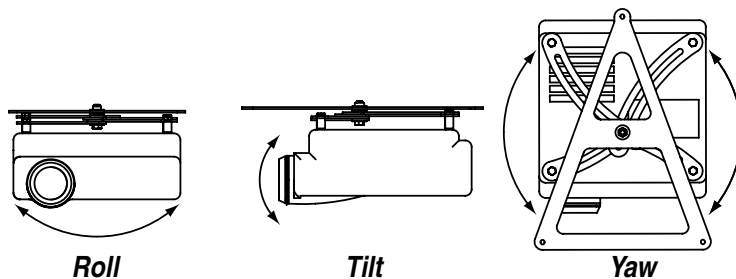

Caution: Beware of pinch point.

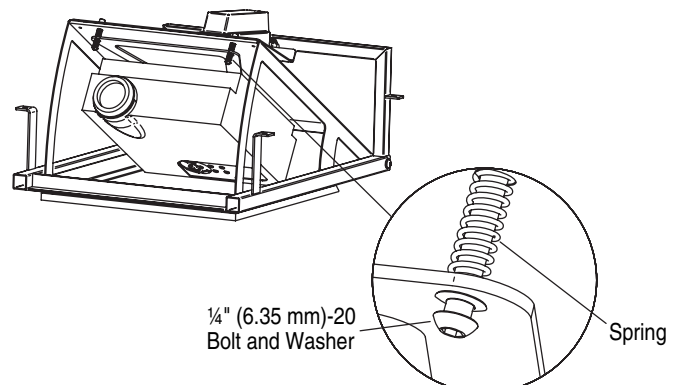
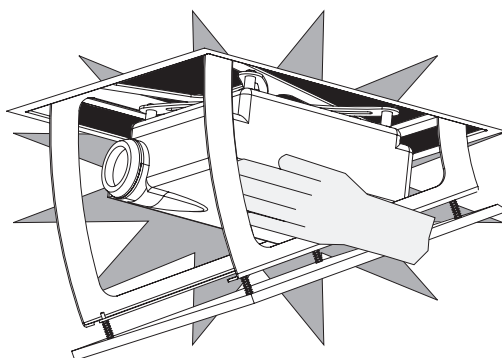

Detail: 1/4" (6.35 mm)-20 bolts and Spring

Wiring Diagrams

Standard Switch Control

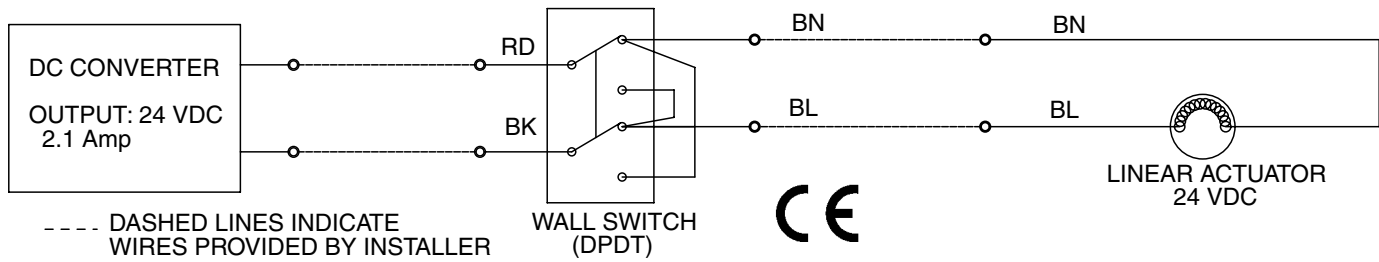

Optional Wireless (RF, IR), RS232 and IP Control

