



NorStone
design

Eker 3

Black

Prices of flat screen TVs is going down every single day, while Quality, Reliability and Design know constant improvements. NorStone Design offers a new piece that perfectly follows this trend.

EKER 3 is the solution for those who decide not to wall mount their flat screen TV.

Its classical and elegant shapes will ideally blend with any kind of home décor. Its "black lacquer" colour will perfectly fit with all the current plasma or LCD finishes.



Specifications

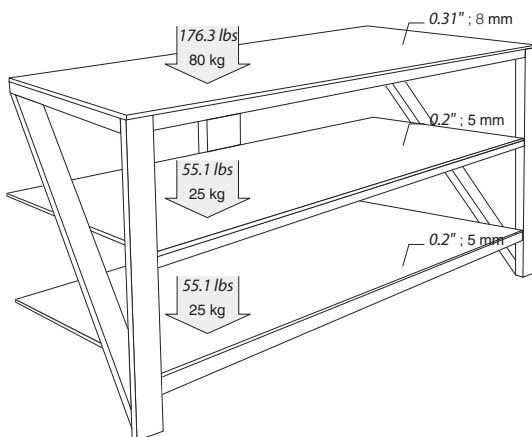

Structure Black powder coated steel.
Shelves: Black lacquered tempered glass.

Maximum load: Top shelf can hold up to 176.3 lbs; 80 kg
Internal shelves can hold up to 55.1 lbs; 25 kg

Dimensions: Overall dimensions: W35.4" x D19.7" x H21.6"
W900 x D500 x H550 mm
Internal shelves: W32.3" x D19.1"
W820 x D485 mm
Superior shelf: W35.4" x D19.7"
W900 x D500
Height between shelves: a: 8.3"; 210 mm
b: 8.5"; 216 mm

Packaging: Delivered in flat box.
Accessories: Screws kit, mounting instructions, mounting tools.

Brown packaging.
Packaging size: W38.2" x D22.8" x H5.5"
W970 x D580 x H140 mm
Gross weight: 63.9 lbs; 29 kg
Net weight: 60.6 lbs; 27,5 kg
Number of labels: 1 front and 1 side.

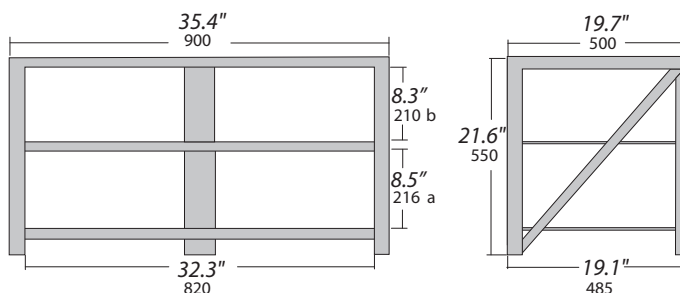

Details



Mise à jour: 19/05/2006