



NorStone
design

Eker 5

Inspired by the previous Eker range, Norstone Design builds up a new piece of furniture called Eker 5. It assembles all of the sought aspects from a piece of furniture in this class. Its uncluttered design and its glossy black finish overcome the boundaries of refinement. Combining stylishness and functionality, it will house easily all kind of electronic devices.



Specifications

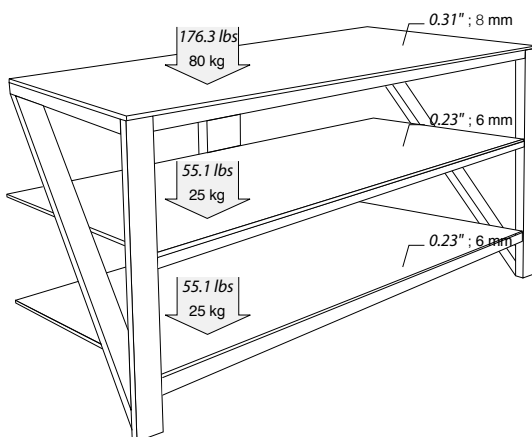

Structure Black powder coated steel.
Shelves: Black lacquered tempered glass.

Maximum load: Top shelf can hold up to 176.3 lbs; 80 kg
Internal shelves can hold up to 55.1 lbs; 25 kg

Dimensions: Overall dimensions: W40.5" x D19.7" x H21.6"
W1030 x D500 x H550 mm
Internal shelves: W37.4" x D19.1"
W950 x D485 mm
Superior shelf: W40.5" x D19.7"
W1030 x D500
Height between shelves: a: 8.3"; 210 mm
b: 8.5"; 216 mm

Packaging: Delivered in flat box.
Accessories: Screws kit, mounting instructions, mounting tools.

Brown packaging.
Packaging size: W45.3" x D24.4" x H4.1"
W1150 x D620 x H105 mm
Gross weight: 71 lbs; 32,2 kg
Net weight: 63 lbs; 28,6 kg
Number of labels: 1 front and 1 back.

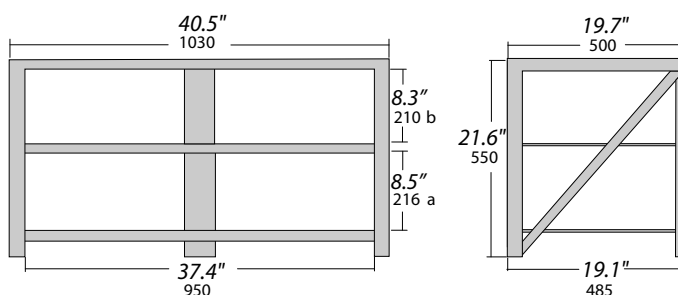

Details

