

Wooden



This AV furniture combines solid wood and lacquered glass. Its contemporary touch makes it easy to integrate in any kind of decor.

The three shelves can smartly welcome a wide range of Home Theatre equipments. The invisible steel structure is designed to maximise the safety of the entire installation.

The material quality as well as the nice proportions of the Wooden offer aesthetic and reliable perspectives that will for sure exceed expectations.



SPECIFICATIONS

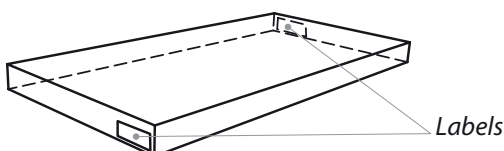
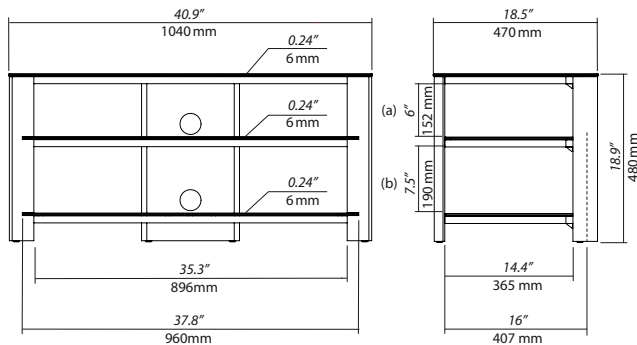
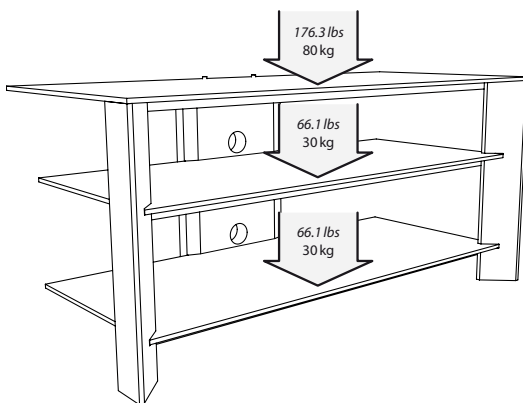

Labels

DESIGN

Finish: Red Pine

Structure: Solid wood

Shelves: Black tempered glass

Miscellaneous: Cable management system

MAXIMUM LOAD

Upper shelf: 176.3 lbs / 80 kg

Internal shelves: 66.1 lbs / 30 kg

USABLE DIMENSIONS

Overall dimensions (W x H x D):

40.9" x 18.9" x 18.5" / 1040 x 480 x 470 mm

Upper shelf (W x D): 40.9" x 18.5" / 1040 x 470 mm

Internal shelves (W x D): 35.3" x 16" / 896 x 407 mm

Height between shelves: (a) 6" / 152 mm

(b) 7.5" / 190 mm

PACKAGING

Delivered disassembled with screws kit, mounting instructions and tools

Quantity/box: 1

Type: Brown cardboard

Dimensions (W x H x D):

48.2" x 3.7" x 25.2" / 1225 x 95 x 640 mm

Gross weight: 75 lbs / 34 kg

Net weight: 60,6 lbs / 27,5 kg

GenCode: 3760108801615