

BAHO

Like anything truly impressive, Baho instantly captivates with its impeccable style, its lines and surfaces as if they were designed by an architect. A flawless creation that is extremely functional for holding all

your electronic components, both sound and video. With its doors closed, Baho has an ultramodern and precious appeal with rare seductive power.

The imagination of NorStone's designers has managed to transform the TV stand into a luxury decorative object. Beyond its style, Baho also offers several advantages: no assembly required, LED* and infrared** kit built in, multidirectional casters discreetly masked, with generous storage spaces throughout the piece. You'll also note the sumptuous glass surfaces that cover the whole unit.

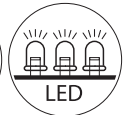

SPECIFICATIONS

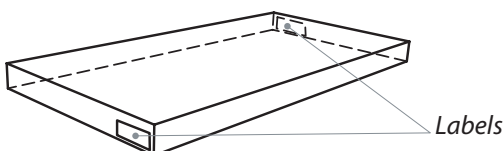
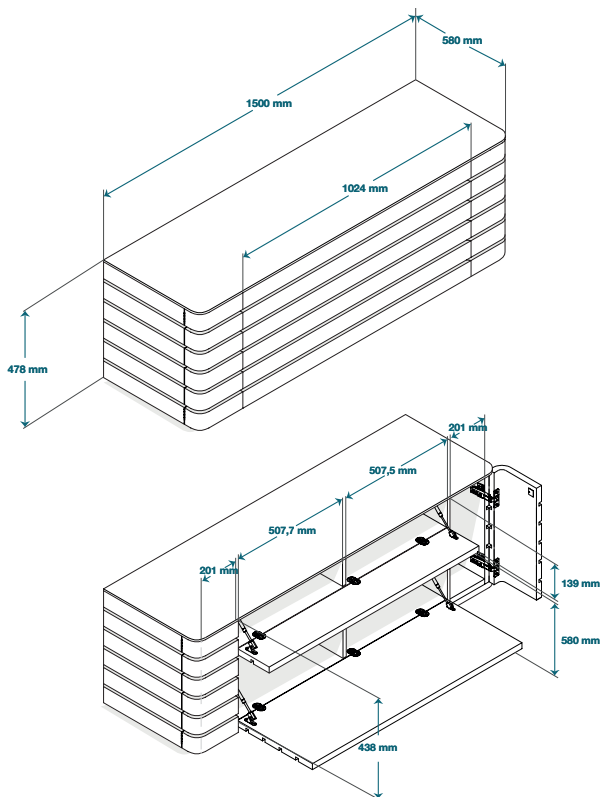

DESIGN

Finishes: Black or white lacquered

Structure: Black or white MDF

Top shelf: Black tempered glass

USABLE DIMENSIONS

Overall dimensions (W x H x D): 1500 x 478 x 580 mm

Upper shelf (W x H x D): 1500 x 580 mm

MAXIMUM LOAD

Upper shelf : 80 kg

Internal shelves : 25 kg

PACKAGING

No assembly required

Quantity/box: 1 – **Type:** Wood case

Dimensions (W x H x D): 1605 X 600 X 600mm

Net Weight: 56 kg

Gross Weight: 62 kg

SKU :

NORBAH150BBKP (black)

NORBAH150BBKUK (black UK)

NORBAH150BWTP (white)

NORBAH150BWTUK (White UK)

GenCode :

3760108808225 (Black/Silver)

3760108808478 (Black/Silver UK)

3760108808409 (White/Silver)

3760108808485 (White/Silver UK)

*The LED kit: When you put your hand inside the unit, LEDs light up automatically thanks to a motion detector. Lights go out automatically after 30 seconds with no movement.

**The infrared kit: with the use of a remote cell, you can control your accessories hidden in the unit, keeping the original remote controls, and without opening doors or cabinets.

WARNING : There may be compatibility issues with some latest generation decoders.