

# A-S1000

Integrated Amplifier

- *High performance amplifier that takes full advantage of the sound quality benefits of balanced amplification*
- *Floating Balanced Power Amplifier*
- *Triple parallel electronic volume and tone controls*



## *HiFi Began with Yamaha*

Yamaha's involvement with and passion for music goes back more than a century, to when we built our first reed organ in 1887. Now we are the world's leading producer of pianos and other musical instruments, and are involved with music in many other ways as well. We manufacture professional recording equipment, we design concert halls and we assist artists at concerts with set up and sound tuning. This knowledge and experience benefits our production of audio components in many ways. We introduced our first HiFi (High Fidelity) turntable in 1954, becoming the first company to actually use the term "HiFi." Thereafter we were one of the first to offer mass-produced, high quality audio equipment, and introduced many legendary stereo components. We hope you enjoy the genuine HiFi experience of Yamaha Natural Sound.

The brilliantly expressive capabilities of Yamaha's floating and balanced design — now available to a wider range of music lovers.

### Yamaha's All-New Approach to Achieving Superior Performance

The development of the modern audio amplifier began in the 1960s with the introduction of full-transistor amplifiers. In the 1970s, pure complementary configured power amps appeared, made possible by high output PNP-NPN transistors, and became the dominant type of analogue amplifier. Now digital amps have become popular for their high conversion efficiency and superior operating precision, as well as for their lower weight, size and heat production as compared to analogue amps. Some manufacturers of audiophile-quality amps are working to improve the traditional pure complementary analogue amplifier, while others are seeking to achieve higher sound quality from digital amplifiers.

But Yamaha has developed a third approach that we believe is superior to the other two. The Floating Balanced Power Amplifier uses patented technologies featuring power transistors with the same polarity at the output stage to achieve completely symmetrical operation.

First introduced in the A-S2000, this method is also used to good effect in the A-S1000, which combines a floating balanced power amp section with a high quality preamp section. Simpler in configuration yet with many of the same sound quality features as the ultra

high-end A-S2000, it will deliver excellent performance with the CD-S1000 Super Audio CD Player and other high quality components.

### High Performance Amplifier that Brings Out the Best of Other Components

The power amp, power supply, and phono EQ circuits that contribute to the A-S1000's high sound quality are identical to those of the A-S2000, while the line amp section and volume and tone circuits are nearly the same. Designed to take full advantage of the excellent sonic qualities of the matching CD-S1000, the A-S1000 will also bring out the best of other high performance components.

### Floating Balanced Power Amplifier

With the A-S2000 and now the A-S1000, Yamaha has taken the bold step of using a floating balanced configuration to update the power amplifier for serious music fans. This method, which is completely different from the pure complementary circuit that has been the main type used for the past four decades, features identical polarity on the plus and minus side of the output stage. By completely isolating the plus and minus sides of the left and right channels of both the NFB and power supplies, it achieves perfectly symmetrical operation in the

output stage. The use of four sets of floating power supply units (not connected to earth), provides further operating precision. The result is very low levels of noise and distortion for exceptionally pure and transparent sound quality.

#### Conventional Power Amplifier

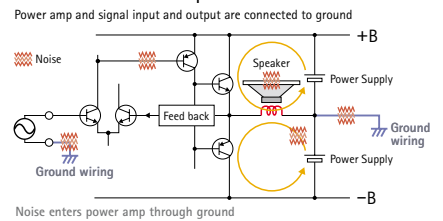

#### A-S1000 Floating Balanced Power Amp

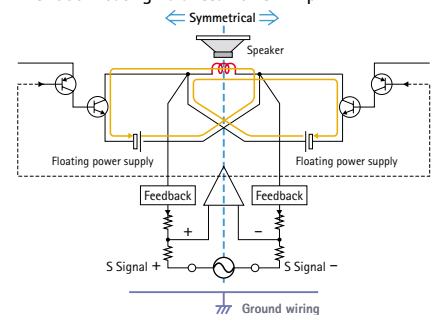

### Triple Parallel Electronic Volume and Tone Controls

Conventional audio amps have the volume and tone control circuits arranged in series (in line); when the tone controls are used, the signal route becomes more complicated, which can lower sound quality. Many high quality amps therefore have a default circuit that can be selected to bypass the tone controls, but this forces you to choose between tone control and optimum quality. The A-S2000 and A-S1000 are the first amplifiers to avoid this problem by employing triple parallel electronic volume and tone controls, providing maximum sound quality even when the tone controls are used (signal goes through fewer ICs, so there is less noise). When the tone controls are set to the center position, the passive element used for tone control is bypassed, so the three volume elements connected in parallel operate solely to drive and control the volume, for more efficient use of the power output. Each volume element is an ultra-high quality device and an analogue potentiometer is used to provide a very smooth operating feel.

### Fully Discrete Phono Equaliser and MC Head Amp

The A-S1000 uses a fully discrete phono equaliser circuit, whose quality is comparable to those in high-end control amps. And with



Completely symmetrical left-right construction.



Large heat sink, huge power transformer, custom-made block capacitors (18,000µF) and preamp board.

### MC Head Amp and Equaliser Amp Block Diagram

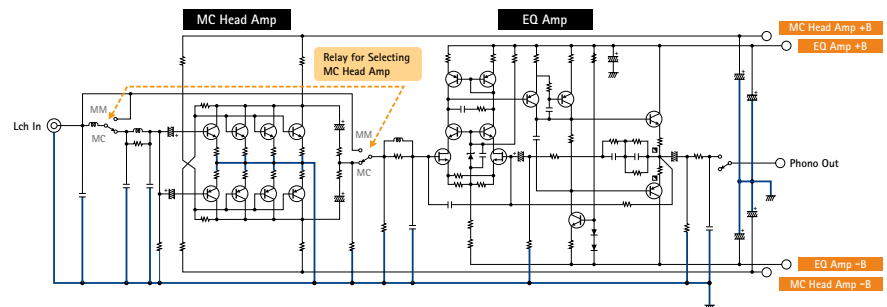

### Conventional Amplifier

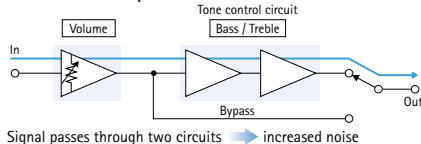

### A-S1000

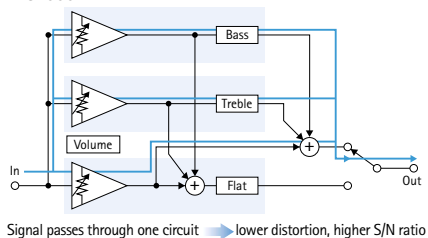

its high priority on maximising musical response, it is also equipped with a discrete head amp for MC cartridges. If you enjoy listening to records via high performance cartridges, the A-S1000 is an ideal choice.

### Power Supply

Power is provided by four large capacity power supplies that are completely isolated from earth. In the preamp stage, the combination of a low-current circuit that prevents the occurrence of noise due to current fluctuation and 12 shunt regulators supply all stages with clean and stable power. The extra-large power transformer, the carbon sheath block capacitors and other

parts that directly affect sound quality were chosen only after extensive testing.

### Symmetrical Construction

Although it is an integrated amplifier, the A-S1000 has a completely left-right symmetrical construction that makes it virtually the equal of separate amps. A central reinforcing bar ensures that the chassis is totally rigid.

### Specially Designed Feet

The base is equipped with height adjustable, solid steel feet that maximise stability and thoroughly dampen any external vibration.



Black finish available.

## A-S1000 Main Specifications

[AUDIO SECTION]		
Maximum Power	(4 ohms, 1 kHz, 0.7 % THD, for Europe)	160 W + 160 W
Minimum RMS Output Power	(8 ohms, 20 Hz–20 kHz, 0.02% THD)	90 W + 90 W
	(4 ohms, 20 Hz–20 kHz, 0.02% THD)	140 W + 140 W
Maximum Power	(8 ohms, 1 kHz, 10% THD)	115 W + 115 W
	(4 ohms, 1 kHz, 10% THD)	190 W + 190 W
Dynamic Power/Channel	(8/6/4/2 ohms)	105/135/190/220 W
Damping Factor	(8 ohms, 20 Hz–20 kHz)	160
Input Sensitivity/Impedance	CD, etc.	150 mV/47 k-ohms
	Phono MM	2.5 mV/47 k-ohms
	Phono MC	100 μV/50 ohms
	Main In	1 V/47 k-ohms
Maximum Input signal	CD BAL, 1 kHz, 0.5% THD	—
	CD, etc, 1 kHz, 0.5% THD	2.8 V
Frequency Response	CD, etc. to Speaker Out, Flat Position	5 Hz–100 kHz, +0 dB/-3 dB
	CD, etc. to Speaker Out, Flat Position	20 Hz–20 kHz, +0 dB/-0.3 dB
Total Harmonic Distortion (20 Hz–20 kHz)	CD, etc. to Speaker Out	0.015% (90 W/8 ohms)
	Phono MM to Rec Out	0.005% (2 V)
	Phono MC to Rec Out	0.05% (2 V)

Signal-to-Noise Ratio [IHF-A Network]	CD, etc. (150 mV, Input Shorted)	98 dB
	Phono MM (5mV, Input Shorted)	93 dB
	Phono MC (500 μV, Input Shorted)	85 dB
Residual Noise	CD, etc. [IHF-A-Network]	73 μV
RIAA Equalisation Deviation	Phono MM	20 Hz–20 kHz, ±0.5 dB
	Phono MC	20 Hz–20 kHz, ±0.5 dB
Channel Separation (1 kHz/10 kHz)	CD, etc., Input 5.1 k-ohms Terminated	74 dB/54 dB
	Phono MM, Input Shorted, Vol: -30dB	90 dB/77 dB
	Phono MC, Input Shorted, Vol: -30dB	66 dB/65 dB
Tone Control Characteristics	Bass Boost/Cut (at 50 Hz)	±9 dB
	Bass Turnover Frequency	350 Hz
	Treble Boost/Cut (at 20 Hz)	±9 dB
	Treble Turnover Frequency	3.5 kHz

[GENERAL SECTION]		
Dimensions	(W x H x D)	435 x 137 x 465 mm 17-1/8" x 5-3/8" x 18-5/16"
Weight		22 kg; 48.5 lbs.



The perfect match:



**CD-S1000** Super Audio CD Player

For details please contact:

Visit us at our website:  
<http://www.global.yamaha.com>

 **YAMAHA**  
CREATING 'KANDO' TOGETHER