

GRAND CONCERT

THE FLAG SHIP

Its structure comprises three distinct enclosures designed to ensure elimination of standing waves and vibration.

The considerable weight of the loudspeaker (100 kg) required the development of the new exclusive Fixocal locking system, which locks the three enclosures together with up to 1.6 tons of clamping pressure.

Grand Concert is not just a technological showcase; all of TRIANGLE's passion for music has gone into it. We have pushed our thrive for perfection to its limit.

Bass is abysmally deep, the mids and highs simply go beyond the walls, you can feel the ambiance in the hall and it is totally gripping. At last, you can now enjoy a genuinely realistic listening experience.

With the *Grand Concert*, TRIANGLE's engineers have managed to blend together seemingly incompatible elements: the full texture of the timbre coupled with sublime airiness and power which conserves all its femininity.

In collaboration with Hutchinson, we developed an exclusive coupling process for the T16PG midrange driver. The resulting elimination of any vibration creates a sound image which is totally transparent and exceptionally sharp. This principle of mechanical coupling is drawn upon for the configuration of the filters which are separate and isolated, each one functioning uniquely within its own individual module.



THE CATHEDRAL OF NOTRE-DAME IN AMIENS

MAGELLAN IN THE CATHEDRAL IN AMIENS

The *Grand Concert* was installed for a philharmonic concert in the cathedral in Amiens, which is the most vast medieval edifice in France (it measures 145 m in length, with a 42.5 m vaulted nave and an interior volume of 200 000 m³).

SPEC SYSTEM

An exclusive technology developed by TRIANGLE. Like the endpin of a cello, it evacuates mechanical energy to the ground.

TWEETER TZ 2900 GC

A marvel of mechanical ingenuity and precision machining, one of the cornerstones of the Magellan program.

CONNECTOR BLOCK

Made of pure copper and plated with gold to ensure perfect electric conductivity.



Magellan
BECAUSE YOU DESERVE THE BEST.

GRAND CONCERT

The Grand Concert loudspeaker which has required more than 1 000 design plans throughout its development stages, is the culmination of professional craftsmanship and a passionate desire. It represents the very heart and soul of TRIANGLE.



High-gloss lacquer finish available in Black or White on *Grand Concert*.

Handcrafted in France
www.triangle-fr.com

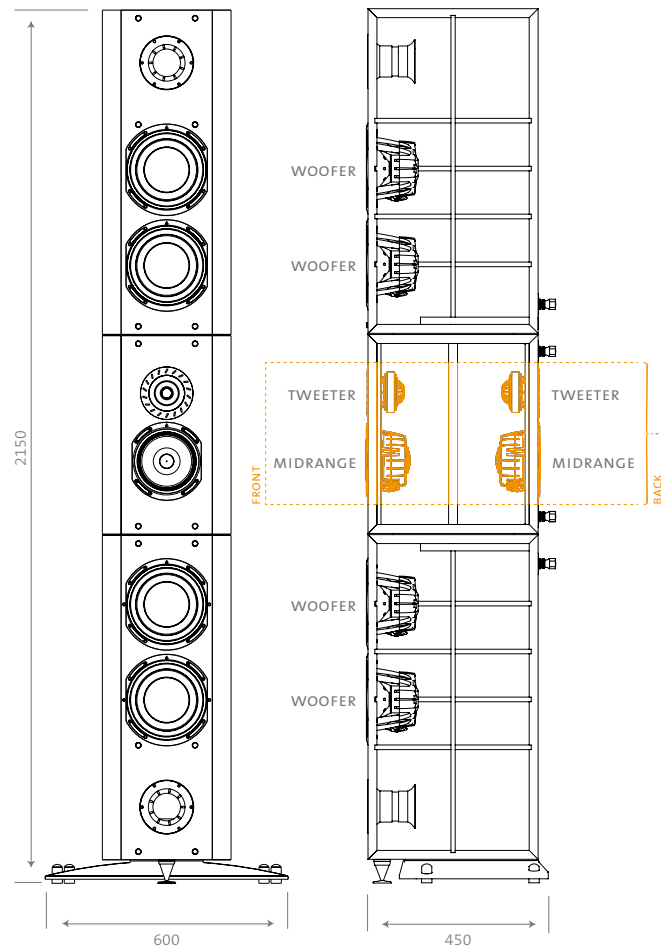
MAGELLAN UNIQUE SYSTEM

The **BI-POLAR** arrangement is designed to faithfully reproduce the soundstage by diffusing a 360° sound image.

NUMBER OF DRIVERS	8
NUMBER OF WAYS	3
TWEETER (2x)	TZ2900GC
MIDRANGE (2x)	T16GMF100-THG06
WOOFER (4x)	T21GM-MT10-THG06
SENSITIVITY (dB/W/m)	91
FREQUENCY RANGE (+/- 3dB Hz-KHz)	28-20
POWER HANDLING (W)	400
REPETITIVE PEAK POWER	800
SPL MAX (dB)	116
NOMINAL IMPEDANCE (Ω)	4
MINIMUM IMPEDANCE (Ω)	2,5
LOW FREQUENCY ROLL-OFF (Hz)	300 (12dB/Oct)
HIGH FREQUENCY ROLL-OFF (Hz)	2800 (24dB/Oct)
DIMENSIONS (HxLxP mm)	2150 x 600 x 450
WEIGHT (Kg)	100

2x
TWEETER TZ2900GC

Optimized by computer simulation, its horn is shaped to provide a substantial attenuation of the directivity effect, i.e. off-axis drop in high frequency level. A remarkably smooth and fluid musical quality!

2x
MIDRANGE T16GMF100-THG06

A unique design: extra wide bandwidth from 70 Hz to 4000 Hz with minimum distortion and the most linear output in the industry. The new cellulose fiber diaphragm features an exponential profile to ensure true-to-life reproduction in the medium frequency band.

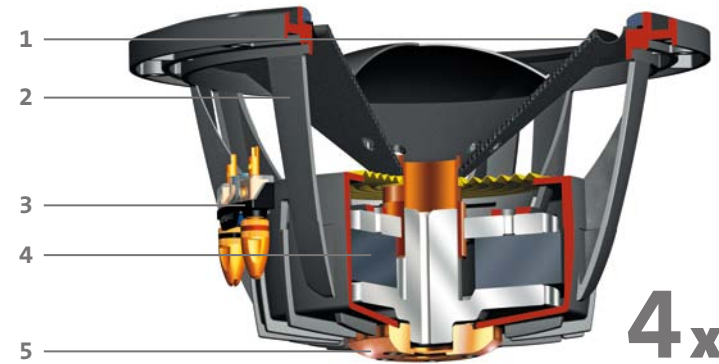
WOOFER T21GM-MT10-THG06

1. Composite diaphragm consisting of an inner cellular structure (cellulose pulp) sandwiched between two sheets of fiberglass (new SVA diaphragm).
2. High rigidity die-cast aluminium basket fitted with a rear cover acting as a radiator.
3. Special connection block on T16PG, T16GM and T21GM series drivers.
4. The special steel alloy polar pieces of the motor provide an extremely powerful magnetic field.
5. Thermal transfer ring designed to dissipate the heat generated by the motor (LHS2 System).



Magellan
by TRIANGLE

GRAND CONCERT

Magellan

CONCERTO

A GRAND DAME.

This is a music lover's loudspeaker *par excellence*, and faithfully reproduces each musical detail. The *Concerto* is capable of letting leash the full force of a symphonic orchestra or delicately revealing the slightest inflection of a single voice. It can deal with all types of music with extreme ease, from the most intangible to the most frantic.

Explosive dynamics, deep bass, crisp treble and emphasis on tonal quality: it's all in there and brought together effectively to produce a sense of openness. The optimized sound layering makes you forget you are listening to a loudspeaker.

This true to life experience is the result of the determined efforts of the men and women who make up the TRIANGLE team, and their deep passion for music.

The filter, which is designed according to the same stringent quality standards as all of the loudspeaker's components, orchestrates this masterpiece wonderfully.

With the *Concerto* the concert invites itself into your own home.



« ... MY EARS BECOME ALL JUBILANT... »

«It's a real pleasure to know you can trust TRIANGLE for their sound quality. The sound and even the silence are so stylish that it's a real inspiration. My ears become all jubilant and my musical intellect is stimulated by the high fidelity to which I am so happy to have got used to. I can't wait to record and mix my new albums with my TRIANGLE... Thanks!»

STEVE SHEHAN

Composer, percussionist and multi-instrumentalist.

STEVE SHEHAN

A rear view of the Midrange



A few steps in the driver assembly process.



Magellan

BECAUSE YOU DESERVE THE BEST.

CONCERTO

Imagined as being a Grand Dame, she knows how to step aside, leaving the stage only to the music. She can deal with all types of music with an extreme ease, from the most intangible to the most frantic.

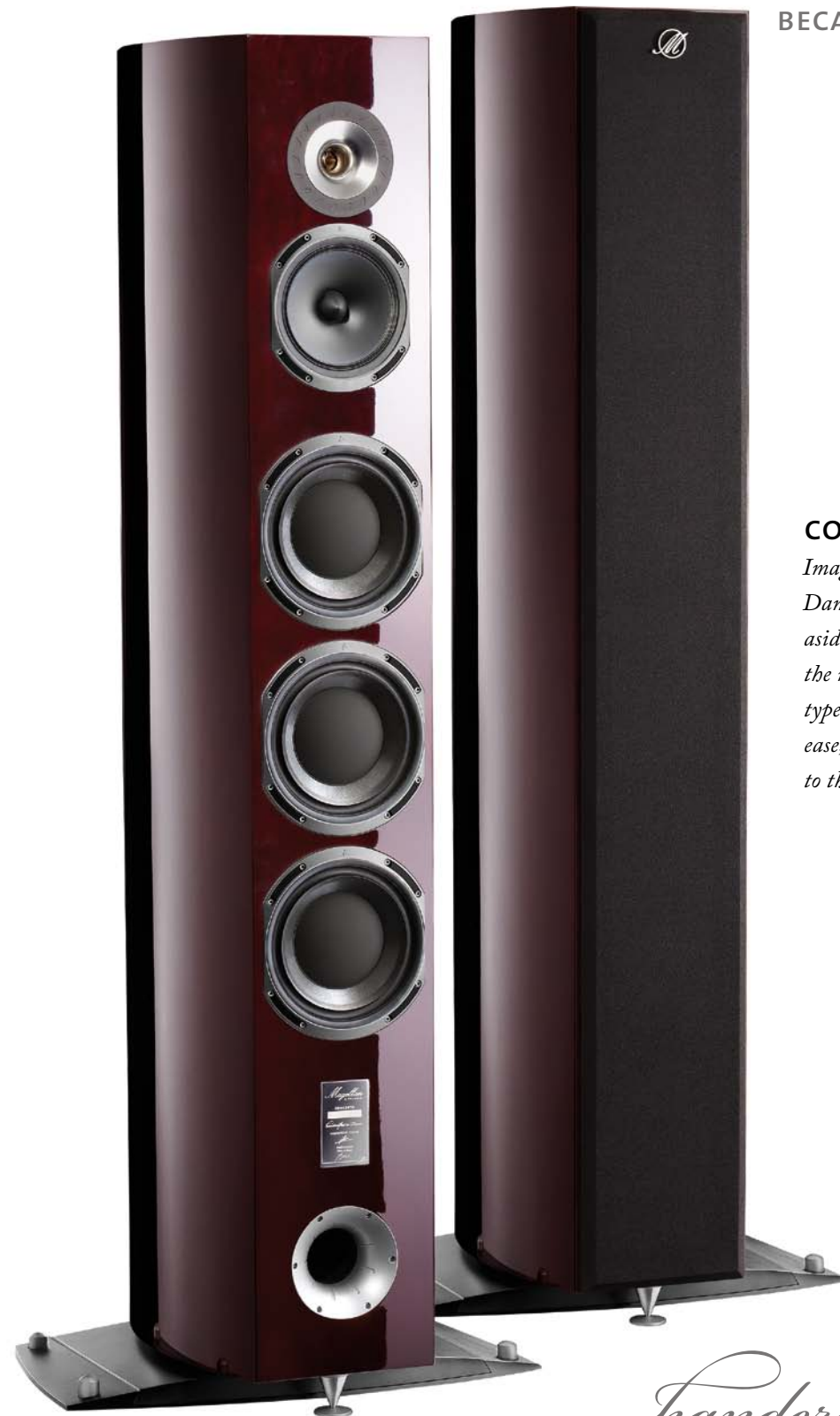

High-gloss lacquer finish available in Black, White, Mahogany or Bubinga on *Concerto*.

Handcrafted in France

MAGELLAN UNIQUE SYSTEM

The **BI-POLAR** arrangement is designed to faithfully reproduce the soundstage by diffusing a 360° sound image.

NUMBER OF DRIVERS	7
NUMBER OF WAYS	3
TWEETER (2x)	TZ2900 GC
MIDRANGE (2x)	T16GMF100-THG06
WOOFER (3x)	T21GM-MT15-THG06
SENSITIVITY (dB/W/m)	90
FREQUENCY RANGE (+/- 3dB Hz-KHz)	32 – 20
POWER HANDLING (W)	300
REPETITIVE PEAK POWER	600
SPL MAX (dB)	114
NOMINAL IMPEDANCE (Ω)	4
MINIMUM IMPEDANCE (Ω)	2,5
LOW FREQUENCY ROLL-OFF (Hz)	300 (12dB/Oct)
HIGH FREQUENCY ROLL-OFF (Hz)	2800 (24dB/Oct)
DIMENSIONS (HxLxPmm)	1600 x 600 x 450
WEIGHT (Kg)	65

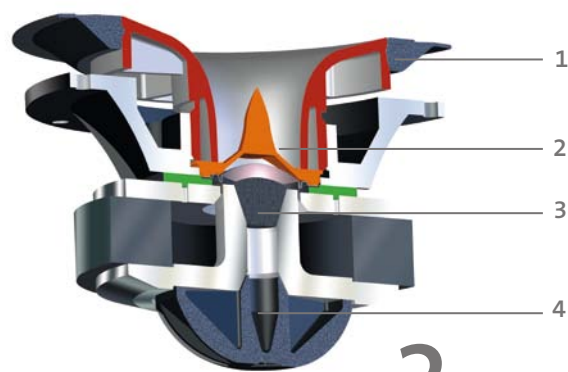
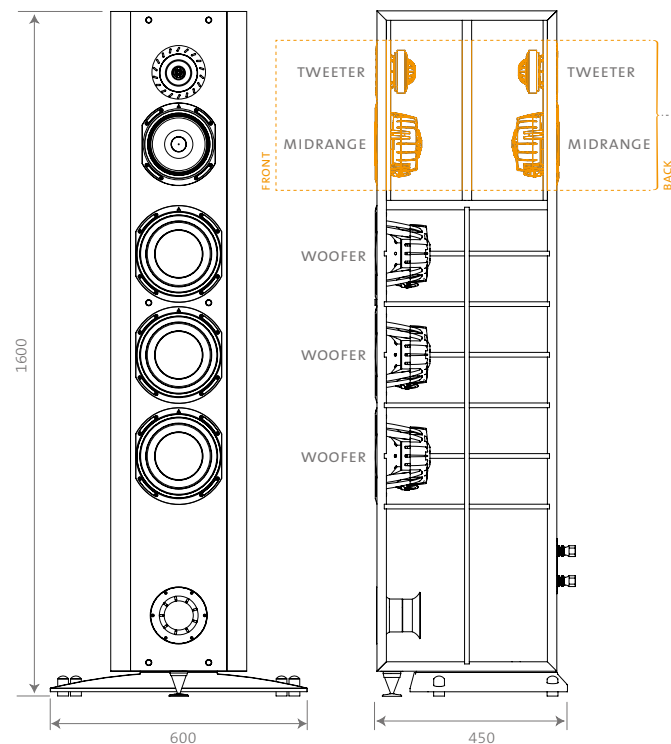
2x
TWEETER TZ2900 GC

1. Support ring fitted directly between the horn to the cabinet. Its outer surface is dimpled to linearize the high end of the spectrum.
2. Matched geometries: the horn/phase plug are complementary to improve the linearity of the frequency response curve.
3. A damping piece in the central passage mounted just under the dome also contributes to a very substantial reduction in distortion.
4. Rear cover made of synthetic material. Its depth which is adjusted according to the wavelengths enables the TWEETER to produce improved frequency response.



2x
MIDRANGE T16GMF100-THG06

A unique design: extra wide bandwidth from 70Hz to 4000Hz with minimum distortion and the most linear output in the industry.

The new cellulose fiber diaphragm features an exponential profile to ensure true-to-life reproduction in the medium frequency band.

3x
WOOFER T21GM-MT15-THG06

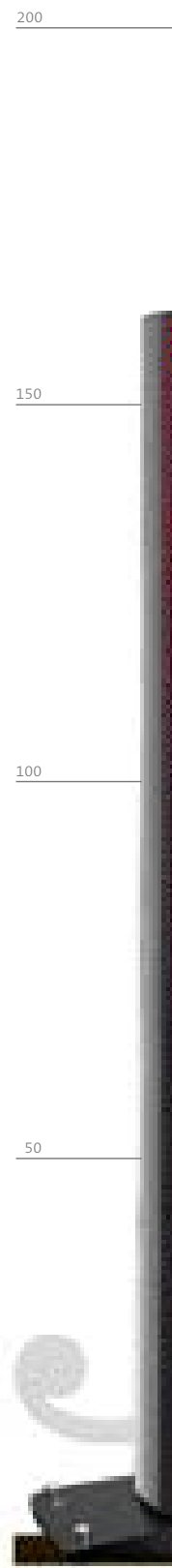
In the MAGELLAN range, the WOOFERS deliver realistic acoustic levels with minimum distortion.



Magellan
by TRIANGLE

CONCERTO

Magellan

QUATUOR

MUSIC LIKE AT THE OPERA.

Sound image has now entered a new dimension. *Quatuor* masters the stage with such elegance.

The rear tweeter has opened wide the gates to freedom. It is stylishly sleek and refined.

You can easily imagine the musicians playing pianissimo to the rear of the orchestra.

Quatuor lets you listen to music without having to ask yourself any questions. Three 16 cm speakers producing powerful, full-bodied bass can deal just as easily with modern types of music as they can with a prestigious string quartet or a cello suite.

A high-end loudspeaker. A loudspeaker to be experienced.



Photo F. Hénin

JEAN-LUC PONTY

« ... SOUND REPRODUCTION IS SO FAITHFULLY REALISTIC... »

«It took me only a few seconds to hear the undeniable superiority of a **TRIANGLE** loudspeaker compared to other professional loudspeakers: sound reproduction is so faithfully realistic and harmonics are sumptuous»

JEAN-LUC PONTY

Jazz violinist and 'pioneer of the electric violin'

The Research and Development team.

The Acoustics labs.

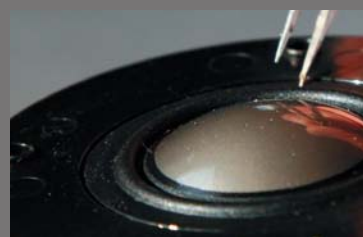

Magellan

BECAUSE YOU DESERVE THE BEST.

QUATUOR

A unique experience among high-end loudspeakers.



High-gloss lacquer finish available in Black, White, Mahogany or Bubinga on *Quatuor*.

Handcrafted in France

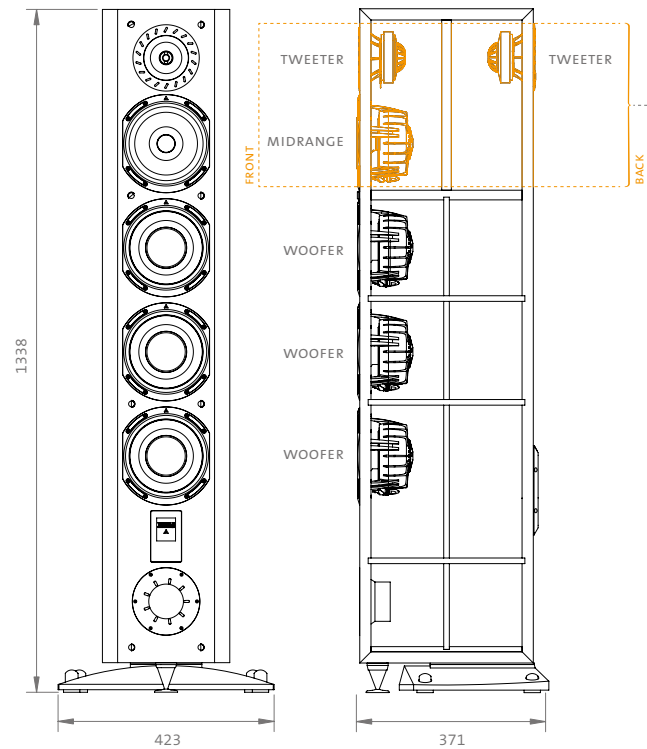
MAGELLAN UNIQUE SYSTEM

The **BI-POLAR** arrangement is designed to faithfully reproduce the soundstage by diffusing a 360° sound image.

NUMBER OF DRIVERS	6
NUMBER OF WAYS	3
TWEETER (2x)	TZ2900 GC
MIDRANGE	T16GMF100-THG06
WOOFER (3x)	T16GM-MT15-GC2
SENSITIVITY (dB/W/m)	90
FREQUENCY RANGE (+/- 3dB Hz-KHz)	33 – 20
POWER HANDLING (W)	260
REPETITIVE PEAK POWER	500
SPL MAX (dB)	113
NOMINAL IMPEDANCE (Ω)	8
MINIMUM IMPEDANCE (Ω)	3
LOW FREQUENCY ROLL-OFF (Hz)	400 (12dB/Oct)
HIGH FREQUENCY ROLL-OFF (Hz)	2800 (24dB/Oct)
DIMENSIONS (HxLxPmm)	1338 x 423 x 371
WEIGHT (Kg)	45

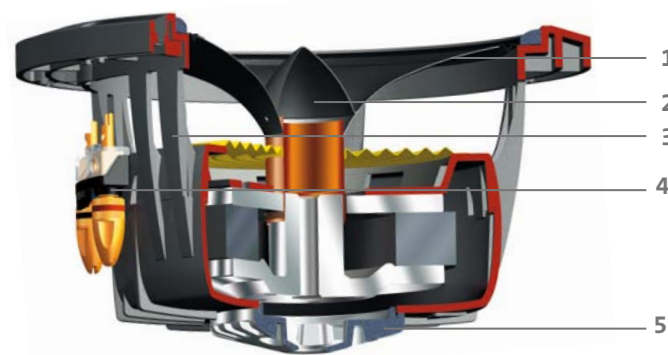
1x
MIDRANGE T16GMF100-THG06

1. The new diaphragm, made of latex-impregnated textile fibres, has an improved profile and an S-shaped suspension for optimum flexibility.
2. The System features an ultra light cone attached to the diaphragm. This part is molded in polypropylene and covered with a high damping latex.
3. Die-cast aluminium basket. The rear cover is shaped to act as a heat dissipator.
4. Special connection block on T16PG, T16GM and T21GM series drivers.
5. This heat transmission ring optimizes the heat transfer to the rear cover (LHS2System).

2x
TWEETER TZ2900 GC

Optimized by computer simulation, its horn is shaped to provide a substantial attenuation of the directivity effect, i.e. off-axis drop in high frequency level. A remarkably smooth and fluid musical quality!

3x
WOOFER T16GM-MT15-GC2

In the MAGELLAN range, the WOOFERS deliver realistic acoustic levels with minimum distortion.



200

150

100

50



Magellan
 by TRIANGLE

QUATUOR

 94 . . . 96 . . . 98 . . . 100 . . . 102 . . . 3
 ■ GRAND CONCERT ■ CONCERTO ■ QUATUOR ■ CELLO ■ DUETTO ■ VOCE

Magellan

CELLO

THE REFERENCE LOUDSPEAKER.

When listening to this loudspeaker, the magic of music unfurls before you. TRIANGLE has succeeded in adapting the performances and the immaculate control of the **MAGELLAN Grand Concert** to this reasonably sized loudspeaker.

Cello provides that extra something which conveys the intense emotion of a musical performance without appearing to make any particular effort.

The listening experience is pure unlimited pleasure regardless of the type of music, delivered with magnificent scale and it's never tiring. It has a wide array of musical skills. It's as perfectly at ease at high volume level as it is for intimate listening, and is suitable for rooms measuring 25 to 50m². The sandwich technology developed by the aerospace industry ensures that the two bass drivers are extremely lightweight and also particularly rigid.



Photo F. Houis

«... **TRIANGLE**. It's the speaker that gets closest to what we really hear. It respects and reproduces the whole register from bass to treble with full precision and without over doing it. I fully heartedly recommend them to all professionals and enthusiasts that I meet, and I know why...»

THIERRY ARPINO

Jazz drummer in New York

THIERRY ARPINO

SPEC SYSTEM

An exclusive technology developed by TRIANGLE. Like the endpin of a cello, it evacuates mechanical energy to the ground.

TWEETER TZ 2900 GC

A marvel of mechanical ingenuity and precision machining, one of the cornerstones of the Magellan program.

CONNECTOR BLOCK

Made of pure copper and plated with gold to ensure perfect electric conductivity.



Magellan
BECAUSE YOU DESERVE THE BEST.

CELLO

All the technologies of the Grand Concert in a reasonably sized loudspeaker. Without even realizing it, you are tapping your feet. You are in the heart of the music and you want the moment to last...



High-gloss lacquer finish available in Black, White, Mahogany or Bubinga for *Cello*.

Handcrafted in France

TECHNICAL SPECIFICATIONS

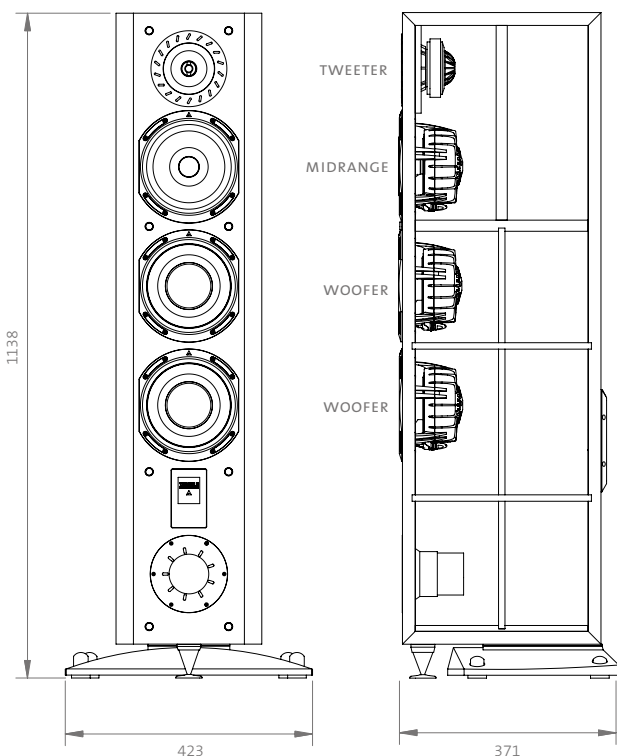

NUMBER OF DRIVERS	4
NUMBER OF WAYS	3
TWEETER	TZ2900 GC
MIDRANGE	T16GMF100-THG06
WOOFER (2x)	T16GM-MT15-GC2
SENSITIVITY (dB/W/m)	91
FREQUENCY RANGE (+/- 3dB Hz-KHz)	35 – 20
POWER HANDLING (W)	200
REPETITIVE PEAK POWER	350
SPL MAX (dB)	112
NOMINAL IMPEDANCE (Ω)	8
MINIMUM IMPEDANCE (Ω)	3
LOW FREQUENCY ROLL-OFF (Hz)	400 (12dB/Oct)
HIGH FREQUENCY ROLL-OFF (Hz)	2800 (24dB/Oct)
DIMENSIONS (H x L x P mm)	1138 x 423 x 371
WEIGHT (Kg)	34



1x

TWEETER **TZ2900 GC**

Optimized by computer simulation, its horn is shaped to provide a substantial attenuation of the directivity effect, i.e. off-axis drop in high frequency level. A remarkably smooth and fluid musical quality!



1x

MIDRANGE **T16GMF100-THG06**

A unique design: extra wide bandwidth from 70 Hz to 4000 Hz with minimum distortion and the most linear output in the industry. The new cellulose fiber diaphragm features an exponential profile to ensure true-to-life reproduction in the medium frequency band.



2x

WOOFER **T16GM-MT15-GC2**

In the MAGELLAN range, the WOOFERS deliver realistic acoustic levels with minimum distortion.

150

100

50

Magellan
 by TRIANGLE

CELLO



94 ····· 96 ····· 98 ····· 100 ····· 102 ····· 3

■ GRAND CONCERT ■ CONCERTO ■ QUATUOR ■ CELLO ■ DUETTO ■ VOCE

THE MAGELLAN FAMILY



NUMBER OF DRIVERS	8	7	6	4
NUMBER OF WAYS	3	3	3	3
TWEETER	TZ2900GC (2 x)	TZ2900GC (2 x)	TZ2900GC (2 x)	TZ2900GC
MIDRANGE	T16GMF100-THG06 (2 x)	T16GMF100-THG06 (2 x)	T16GMF100-THG06	T16GMF100-THG06
WOOFER	T21GM-MT10-THG06 (4 x)	T21GM-MT15-THG06 (3 x)	T16GM-MT15-GC2 (3 x)	T16GM-MT15-GC2 (2 x)
SENSITIVITY (dB/W/m)	91	90	90	91
FREQUENCY RANGE (+/- 3dB Hz-KHz)	28 – 20	32 – 20	33 – 20	35 – 20
POWER HANDLING (W)	400	300	260	200
REPETITIVE PEAK POWER	800	600	500	350
SPL MAX (dB)	116	114	113	112
NOMINAL IMPEDANCE (Ω)	4	4	8	8
MINIMUM IMPEDANCE (Ω)	2,5	2,5	3	3
LOW FREQUENCY ROLL-OFF (Hz)	300 (12dB/Oct)	300 (12dB/Oct)	400 (12dB/Oct)	400 (12dB/Oct)
HIGH FREQUENCY ROLL-OFF (Hz)	2800 (24dB/Oct)	2800 (24dB/Oct)	2800 (24dB/Oct)	2800 (24dB/Oct)
DIMENSIONS (HxLxP mm)	2150 x 600 x 450	1600 x 600 x 450	1338 x 423 x 371	1138 x 423 x 371
WEIGHTS (Kg)	100	65	45	34

150

100

50

Magellan
by TRIANGLE

COMPACT SPEAKERS:
STANDMOUNT AND CENTER SPEAKER



■ GRAND CONCERT ■ CONCERTO ■ QUATUOR ■ CELLO ■ DUETTO ■ VOCE

VOCE

This center speaker is the complementary element for your Home Theater installation and is required, above all to reproduce dialogue. It is positioned under the screen, placed on the TS300 stand or it can even be placed on the floor. Its closed box reproduces voices which sound extremely warm and precise. A lot of work went into studying directivity in order to solve the headache of optimal positioning, which is a common problem with this type of speaker.

Voce is TRIANGLE's response for improving the performance of home theater and multichannel music systems!

«I am rediscovering what 'sound' really means, that's exactly the impression I get when I'm listening to TRIANGLE speakers. The pure pleasure of sound at its most perfect; it's simply joy to my ears»

PHILIPPE GLORIOSO, photographer



*H*igh-gloss lacquer finish available in Black, White, Mahogany or Bubinga on *Voce*.

TECHNICAL SPECIFICATIONS VOCE

NUMBER OF DRIVERS	3
NUMBER OF WAYS	2
TWEETER	TZ2900MS
MIDRANGE - WOOFER	T16GM-F72MS-MR1
SENSITIVITY (dB/W/m)	91
FREQUENCY RANGE (+/- 3dB Hz-KHz)	50 - 20
POWER HANDLING (W)	100
REPETITIVE PEAK POWER	200
NOMINAL IMPEDANCE (Ω)	8
MINIMUM IMPEDANCE (Ω)	4
HIGH FREQUENCY ROLL-OFF (Hz)	2400 (24dB/Oct)
DIMENSIONS (HxLxPmm)	250 x 600 x 375
WEIGHT (Kg)	19
BASE (option)	TS300

DUETTO

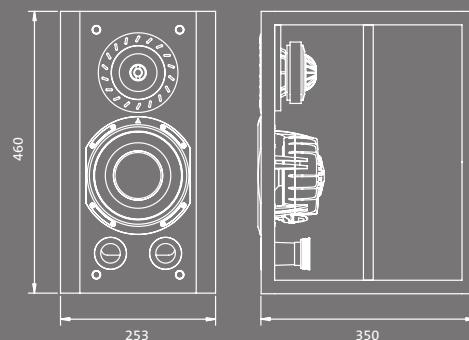

THE « PURE EXTRACT » OF MAGELLAN.

Liveliness and dynamics are hallmarks of TRIANGLE's sound and they are packed into this gem, which takes up so little space.

Being so compact, this loudspeaker will fit effortlessly into rooms measuring 12 to 30 m², producing the same performances as a column speaker with meticulous bass precision and depth. Its compression tweeter reveals the most delicate details of your sound recordings and blends in perfectly with TRIANGLE's famous midrange driver.

Duetto reproduces such clarity that the loudspeakers suddenly vanish, simply to be replaced by the music.

A lightweight paper cone bass-midrange combined with a twin vent system produces rich bass detail.

Its sophisticated filter featuring polypropylene capacitors optimizes the process of phasing bass and treble, resulting in astonishing transparency.

Duetto is a benchmark speaker for the recording studios in Meudon. Technological wizardry for a loudspeaker consisting of only two drivers, which just goes to prove that TRIANGLE is the master in the field.

*H*igh-gloss lacquer finish available in Black, White, Mahogany or Bubinga on *Duetto*.

TECHNICAL SPECIFICATIONS DUETTO

NUMBER OF DRIVERS	2
NUMBER OF WAYS	2
TWEETER	TZ2900 GC
MIDRANGE - WOOFER	T16GM-MT10-GC1
SENSITIVITY (dB/W/m)	88
FREQUENCY RANGE (+/- 3dB Hz-KHz)	38 - 20
POWER HANDLING (W)	80
REPETITIVE PEAK POWER	160
SPL MAX (dB)	107
NOMINAL IMPEDANCE (Ω)	8
MINIMUM IMPEDANCE (Ω)	4
HIGH FREQUENCY ROLL-OFF (Hz)	2800 (24dB/Oct)
DIMENSIONS (HxLxPmm)	460 x 253 x 350
WEIGHT (Kg)	16
BASE (option)	TS400

DUETTO



Magellan
BECAUSE YOU DESERVE THE BEST.



DUETTO

«Such elegant and superbly manufactured speakers can only but thrill the most discerning of audiophiles...»

JEAN-PAUL GONNOD
Sound ingeneer at the Meudon recording studios (Paris - France)

Handcrafted in France
www.triangle-fr.com